

CD-6208

Multi Source Player...

SD / USB / CD / Multi Source Player
Instant Playback from SD Memory
High Quality DAC - Burr Brown PCM-1796



CD-6208 Multi Source Player

High Performance at affordable price”

The CD-6208 was designed from Inter-M's 30 years of research and development experience in Sound Equipment products. The CD-6208 is a multi-source player that can hold in memory the content of up to 6 standard Compact Discs. Memory playback gives instant access to stored tracks. Sound files can be recorded via an external microphone or analogue audio input.

The CD-6208 uses high-quality audio DAC chip. The built-in memory can store up to 6 virtual CD disks and playback as a virtual carrousel player. Among the supported media are CD-DC, CD MP3 and USB.





Virtual disk / INSTANT and AUTO PLAY / PITCH / CUE

Multifunction encoder quality-driven circuit design

Digital, COAXIAL and OPTICAL outputs

Serial 3rd Party control AMX / CRESTRON / INTER-M /

Multi-format Audio playback



»»» CD-6208

The CD-6208 offers high quality playback of multi-format audio on CD, internal virtual memory and removable SD card. Up to 6 entire CD's can be stored each in one of the 6 dedicated virtual CD internal memory location. Tracks from the virtual stored CDs can be assigned to 10 instant play buttons. This allows for immediate instant playback of stored tracks. Inter-M raises the quality standard of CD players by using only high-quality DACs and broadcast quality balanced output stages. 3rd party control such as crestron and AMX is possible via RS-232 control. The CD-6208 is a high-quality yet affordable CD/MP3 player.

CD-6208 Multi Source Player

Virtual CD changer:

Built-in 6 disc virtual cd changer

6 discs can be memorized in one of the 6 virtual CD zones of the SD Card. The virtual disks can easily be accessed for playback in the same manner as conventional CD changers. Unlike CD changers the virtual changer has easier and better access time. Virtual disks means longer pick up and overall product life because it does not have all the traditional mechanical components.

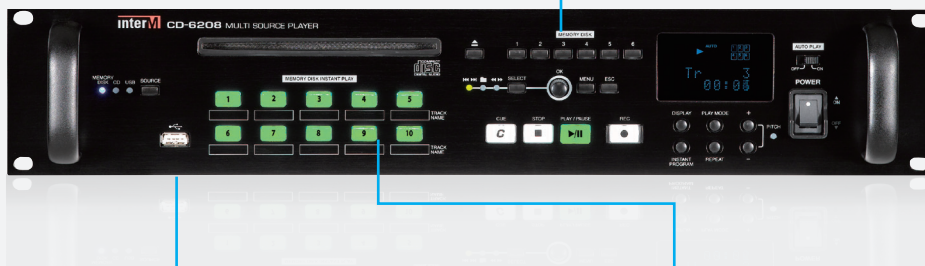
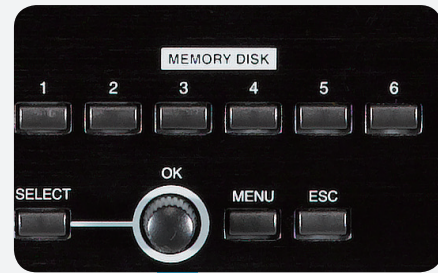

USB Playback

The CD-6208 can easily playback file stored on a USB Drive in formats including MP3, WMA and WAV.

CD PLAYER : 3-beam Pick-Up Robust state-of-the-art transport mechanisms

CD PLAYER : 3-beam Pick-Up
Robust state-of-the-art transport mechanisms



INSTANT PLAY: disk memory, instant replay

10 instant playback buttons allow for immediate access an play back of stored audio files. LED indicators confirm the file in play mode. Ideal for frequently played track to be used in events, theater, broadcast and in musical performance.



AUTO PLAY: Automatic playback on Power 'ON'

The Auto Play feature enabled the CD-6208 to automatically play any audio program stored in the SD CARD, USB or internal virtual CD changer. The CD-6208 can be used with inter-M Power distributor and timer product the CD-6208 can start and stop BGM programs at given times of day.



CUE / PITCH: Playback standby, tempo adjustment

Cue play allows for instant start of audio playback.

The PITCH adjusts the play speed of CDs or MP3 discs, SD, USB and internally stored files in virtual CD Changer by ± 15.0 percent in increments of 0.1 percent. The pitch control can be turned on or off for normal playback by pressing the pitch button.

CD-6208 Multi Source Player

Quality-driven circuit design

The CD-6208 uses high-quality Burr Brown PCM-1796 DAC with DSP - Digital Audio Processing. CD-6208, Supports AES/EBU, Fiber optic and coaxial digital I/O. Superior audio quality is achieved using high-quality D to A and A to D combined with broadcast quality analogue OP-AMP for all I/Os.



Switch Mode Power Supply Design

SMPS power supply design ensures smooth and rich sound reproduction.

Professional Balance Inputs And Outputs

High quality balanced audio design ensures very low noise with very high S/N ratio from the I/Os to the headphone output.

High reliability product design

The CD-6208 is designed using only the highest quality components such as Burr Brown PCM-1796 DAC, Neutrik I/O connectors and reliable laser pick-ups. MTBF is higher than 5000 operating hours. Operating temperature ranges from -10 to +40 °C (14 to 104 °F)



AES / EBU: high-quality digital output

Direct digital connection to digital consoles and processors is possible via the AES/EBU I/O. SPDIF and Optical I/O is also available and supported. Suitable for broadcast applications.

AMX/Crestron and Inter-M Systems external remote control

A user – friendly front panel interface combined with RS-232 Control port compatible with AMX, Crestron, Inter-m systems and other 3rd party controllers capabilities provide exceptional control and ease of use.



Various I / O

The CDP-01 multiple I/O formats including AES/EBU, SPDIF and Optical. Analogue inputs for recording and playback outputs are available on stereo un-balanced audio on RCA connectors and on balanced professional XLR Neutrik connectors. A mono summed output is available on an XLR-M connector optimized for mono-environment applications such as BGM.

Support a variety of media

The CD-6208 supports virtual multi disc play back from CD, SD memory and USB drive. The CD-6208 will support high quality playback file format including MP3, WMA and WAV. Compressed files are supported up to 320 kbps compression. Uncompressed WAV format is also supported for High-quality audio playback.

Firmware update

The CD-6208 comes complete with feature rich performance. New features can be added and upgraded via easy to install Firmware updates. Firmware can be updated be downloaded from the inter-M's website as they become available. Performance can be sustained.



CD-6208 Multi Source Player

Front / Rear Panel

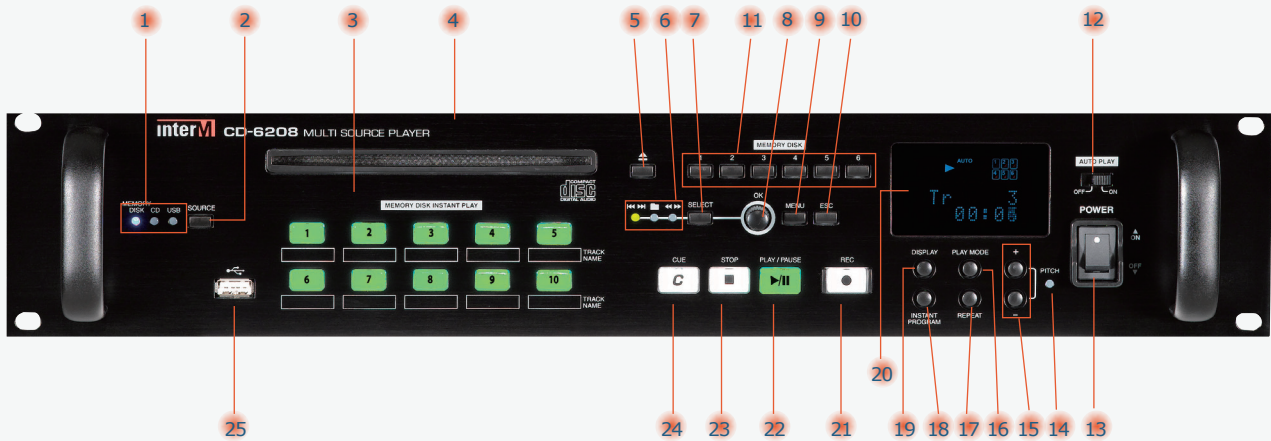

1	Source Selection LED	2	Source Selection	3	Memory Disk Instant Play	4	Disc Slot	5	EJECT
6	Select LED	7	Select	8	Encoder Switch	9	Menu	10	ESC
11	Memory Disk Selector	12	Auto Play Switch	13	Power Switch	14	Pitch LED	15	Pitch (+), (-)
16	Play Mode	17	Repeat	18	Instant Program	19	Display	20	Display Window
21	REC	22	Play/Pause	23	Stop	24	CUE	25	USB Terminal

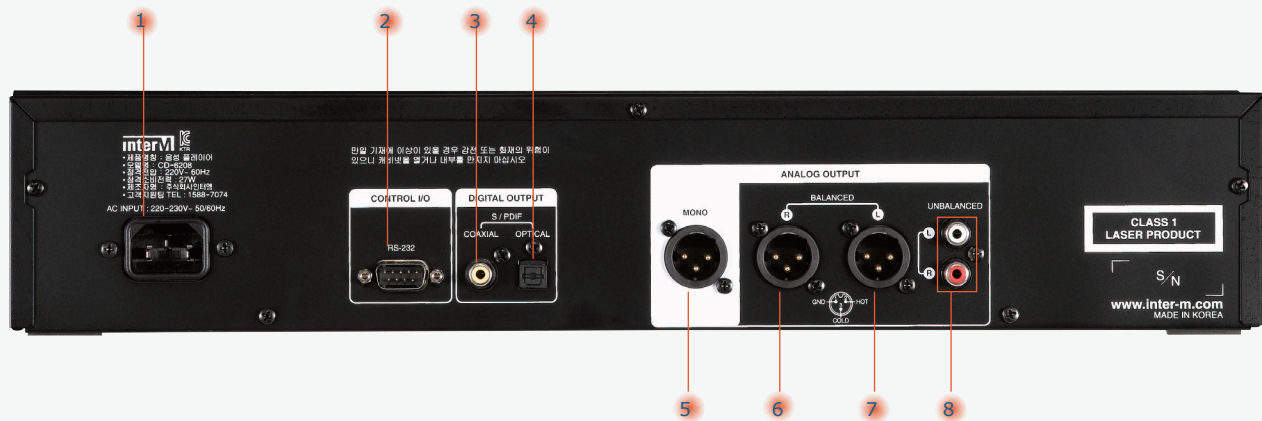

1	AC Inlet	2	RS-232 Interface Socket	3	Coaxial Output Socket	4	Optical Output Socket	5	Mono Output Socket
6	R Channel XLR Output Socket	7	L Channel XLR Output Socket	8	RCA Output Socket				



■ INTER-M CD Player Line-up

CD-610



- Slot-In type 1 Disk CD player
- Uses high-quality DAC
- CD-DA / MP3 / WMA
- AMX, CRESTRON interface (RS-232) support
- IR remote control
- Digital output: SPDIF
- Dimension and Weight:
482(W) x 88(H) x 380(D)mm / 19(W)x3.5(H)x15(D) in
5.8kg / 12.8lb

CD-611



- USB hosting
- Pitch control
- CD copy function
- Uses high-quality DAC
- MP3/WMA
- AMX & CRESTRON interface (RS-232)
- Anti Shock applied
- Dimension and Weight:
482(W) x 88(H) x 380(D)mm / 19(W)x3.5(H)x15(D) in
5.8kg / 12.8lb

CDR-01

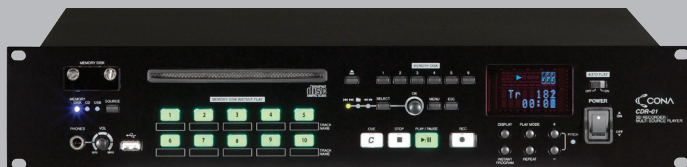

- SD Recorder
- SD Memory Player
- Auto Play
- CUE
- Multifunction encoders
- Sound quality-driven circuit design
- HiFi headphone Monitoring
- AES / EBU output support
- High operating reliability
- 3rd party serial remote control :
AMX / CRESTRON / INTER-M
- Dimension and Weight:
482(W) x 88(H) x 280(D)mm / 19(W)x3.5(H)x11(D) in
5.3kg / 11.7lb
- Virtual Disk
- Instant Play
- Pitch

■ CDR-01/CD-6208 Comparison

Option Model	MEMORY ENCORDING	MEMORY COPY	AUDIO REC TO MEMORY	REMOVABLE SD CARD	AES/EBU CONNECTOR	HEAD PHONE OUTPUT	L/R OUTPUT LEVEL S/W
CDR-01	X	X	O	O	O	O	O
CD-6208	O	O	X	X	X	X	X

Specification

DISC -CD, CD-R, CD-RW	12cm
Number of channels	3 channels (L, R, Mono)
Frequency Response (20Hz~20kHz) -CD, Pitch Off	+0.5/-1.0dB
T.H.D. (20kHz LPF) -CD, 1kHz, Pitch Off	Less than 0.003% (Nor), 0.007% (Lim)
S/N (20kHz LPF, A-WTD) -CD, Pitch Off	Better than 100dB (Nor), 95dB (Lim)
Analog Output Level (Max)	+8 dBu (2Vrms)
Analog Output Connectors	RCA: L/R, XLR: L/R, MONO
Optical Output	SPDIF
Coaxial Output (RCA)	SPDIF
Formats	Audio CD (CD-DA), MP3, WMA
Operation Temperature	-10°C ~ +40°C / 14°F ~ 104°F
Power Source	USA/CANADA 120VAC, 60Hz UK/Europe 230VAC, 50Hz Australia 240VAC, 50Hz
Power Consumption	27W
Weight (SET)	5.3kg / 11.7lb
Dimensions (SET)	482(W) x 88(H) x 280(D)mm / 19(W) x 3.5(H) x 11(D) in

※ Specifications and design are subject to change without notice.

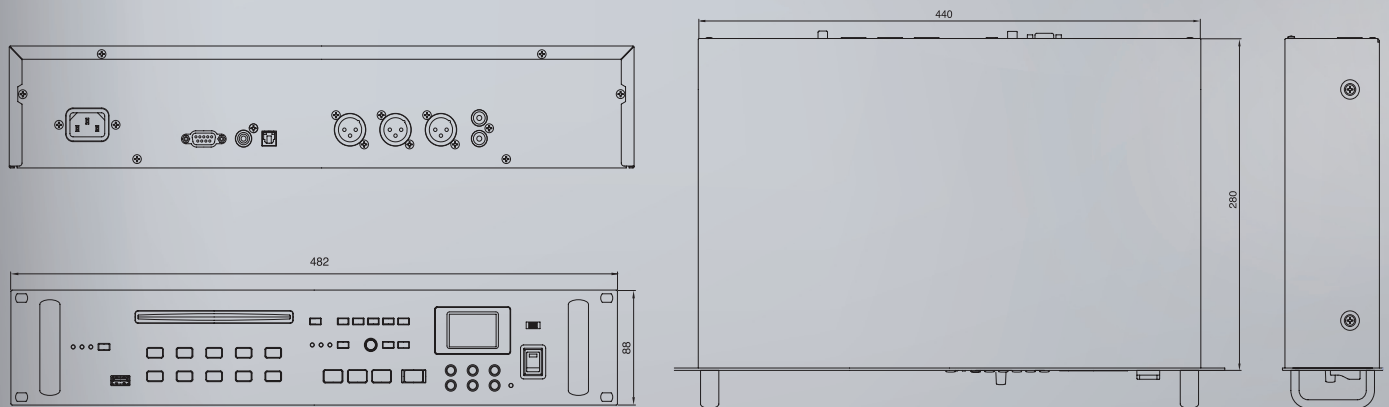

Inter-M Corp. (IMK)

653-5 Banghak-Dong, Dobong-Ku, Seoul, Korea

Overseas Sales Team

Tel_ +82-2-2289-8141~7 Fax_ +82-2-2289-8149 E-mail_ overseas@inter-m.com

www.inter-m.com

※ Design and specification are subject to be changed without pre notice.