

one

User Manual

EN54-16 and EN54-4 Voice Alarm and Public
Address Certified System **LDA ONE**



Table of contents

1 INTRODUCTION.....	6
1.1 System characteristics.....	6
1.2 System diagram	7
1.3 HW and FW versions.....	8
1.4 User interface description.....	8
1.4.1 Light indicators.....	8
1.4.2 Alphanumeric display	9
1.4.3 Controls.....	9
1.5 User profiles. Access level. Passwords	10
2 INSTALLATION INSTRUCTIONS	11
2.1 Orientation change.....	11
2.2 Inputs and outputs	11
2.2.1 Power supply.....	11
2.2.2 Battery installation.....	12
2.2.3 Fire Panel Interface	13
2.2.4 Speaker line outputs	14
2.2.5 Audio source inputs.....	15
2.2.6 ACSI devices and microphones input.....	16
2.2.7 System expansion output. LINK-OUT.....	17
2.2.8 Pre-amplified audio outputs. PRE-AMP OUTPUTS.....	17
2.2.9 Attenuators override output. OVERRIDE 24V.....	17
2.2.10 Internal connections.....	18
2.2.11 Connecting distributed systems.....	18
3 CONFIGURATION AND STARTUP.....	20
3.1 Power supply.....	20
3.1.1 Battery charger installation.....	20
3.1.2 Device closure.....	20
3.2 Automatic Configuration. <Run Autosetup>.....	20
3.2.1 Date and time.....	20
3.2.2 Evacuation messages.	20
3.2.3 Advanced mode selection.....	21
3.3 Manual configuration. <Configuration>.....	22
3.3.1 Audio Inputs. <Audio Inputs>.....	22
3.3.2 Audio Outputs. <Audio Outputs>.....	23
3.3.3 Speaker Lines configuration. <Speaker Lines>.....	24
3.3.4 Configuration of device zones. <Device Zones>.....	24
3.3.5 Import and edit messages. <Messages>.....	25
3.3.6 PA/VA microphones. ACSI devices.....	26
3.3.7 Interface with the fire panel. <CIE>.....	27
3.3.8 Battery Charger. <Battery>.....	27
3.3.9 Save and charge configuration. <Load/Save>.....	28
3.3.10 Device Configuration. <Device>.....	29
3.3.11 System configuration. <System>.....	29
3.4 User management <Login>.....	30

3.5 Multi-device distributed systems.....	30
3.5.1 Introduction.....	30
3.5.2 Individual configuration of each unit.....	31
3.5.3 System setup - Discover operation.....	31
3.5.4 Distributed system operation.....	31
3.6 Advanced configuration.....	32
3.6.1 Advanced configuration variables.....	32
3.6.2 Blocking PA sources in battery and emergency.....	33
3.6.3 Equalizers.....	34
4 SYSTEM USE	35
4.1 Main screen.....	35
4.2 Emergency management. <VA Operator>.....	35
4.2.1 Launch evacuation and alert. <Launch EVAC/ALERT>.....	35
4.2.2 Emergency activation. <Enter EMG>.....	35
4.2.3 Stop voice announcement. <Silence Zones>.....	35
4.2.4 Deactivate emergency. <Reset Zones/Sys EMG>.....	35
4.2.5 VA System monitor. <VA Monitor>.....	36
4.3 Public Address Settings. <PA Operator>.....	36
4.3.1 Volume Settings. <Volume>.....	37
4.3.2 Matrix. <Matrix>.....	37
4.3.3 Monitor. <Monitor>.....	37
4.4 System monitor. <Sys Monitor>.....	37
4.4.1 VA system monitor. <VA Monitor>.....	38
4.4.2 Emergency log. <EMG_Log>.....	38
4.4.3 Fault Log. <FLT_Log>.....	38
4.4.4 System log. <SYS_Log>.....	38
4.4.5 LOGs configuration. <Logs Config>.....	38
4.4.6 System information <Sys Info>.....	38
4.4.7 Test.....	39
5 MAINTENANCE INSTRUCTIONS.....	40
5.1 RESOLUTION OF FAULT INDICATIONS.....	40
5.1.1 Loss of system date and time.....	40
5.1.2 Cover opening protection.....	40
5.1.3 Speaker lines.....	40
5.1.4 Transmission line with CIE	41
5.1.5 Power supply.....	41
5.1.6 Link.....	41
5.1.7 System.....	41
6 TECHNICAL SPECIFICATIONS	42
6.1 EN54-16 functions.....	43

SAFETY INSTRUCTIONS

Please, read carefully these safety instructions.

1. Retain this User Manual for future reference.
2. The device must be connected to a bipolar mains switch according to the Low Voltage Directive, and must be easily accessible for disconnection.
3. The device should not be exposed to dripping or splashing water, and no objects filled with liquids should be placed on the unit. Do not use liquid or spray detergents for cleaning. Do not expose this device to humid areas.
4. No flame sources, such as lit candles, should be placed on the unit.
5. Install this device on a safe surface, applying these User Manual instructions. If you do not place the unit on a safe surface, it may fall and be damaged.
6. Cover grills are for ventilation. **DO NOT COVER THE GRILLS.** To allow proper ventilation, please leave 5 cm on each side.
7. This device should be opened only by qualified or trained personnel.
8. The unit must be connected to an outlet with a protective earthing. When using a non-ducted cable, this must be fixed to the unit with a cable gland to prevent it from being damaged or disconnected.
9. Pay attention to the polarity of the connection when operating the device with a direct current (DC) power supply. If the polarity of the connection is reversed, it can cause damage to the unit, or to the power supply.
10. If any of these situations arise, let technical personnel check the unit:
 - a) The power cord or the plug are damaged.
 - b) Liquid has penetrated inside the device.
 - c) The device has been exposed to moisture.
 - d) The device has not worked properly or does not work according to the User Manual.
 - e) The device has been dropped and damaged.
 - f) If the unit shows any obvious signs of damage.
11. The wiring must be carried out only by trained personnel. Disconnect the audio inputs and outputs while making connections or disconnect the unit from the power supply. Be sure to use the proper cables to make the connections.

1 INTRODUCTION

LDA ONE PA/VA system is certified according to EN 54-16 and EN54-4 requirements, ensuring a safe and controlled emergency evacuation. Its high performance, versatility and audio quality make it a powerful and affordable music and voice distribution system for all kinds of installations. This User Manual is applicable from **FW version v02.00.01.00** onward.

Range of products and accessories for ONE:

- **ONE 500**. Expandable VA central module.
 - **ONE-BC**: Battery management module according to EN54-4
 - **ONE-LOOP**: Expansion card for multi-device distributed systems.
- **TFL2**. Speaker Line terminator.
- **MPS-8Z**. Expandable 8-zone microphone station.
- **VAP-1**. Voice Alarm Panel with optional zone selection.

Other accessories:

- **ONE-WMA** Wall Mount Brackets and **ONE-RMA** rack.

1.1 System characteristics.

Each ONE unit consists of an EN54-16 system capable of controlling a maximum of 6 zones and delivering a maximum total power of 500W. In addition, it is possible to create larger systems by linking several ONE units, allowing the control of up to 60 zones with an overall power of up to 5000W.

Characteristics of each ONE unit:

- Up to 6 zones
- 6 amplified audio outputs for speaker lines
- 4 pre-amplified audio outputs
- 3 physical audio inputs, 2 of them with dynamic request for speech
- 1 internal mixer that can generate an additional MIX source from the 3 physical inputs
- ACSI port for connection of up to 8 microphones or fire panels
- Internal memory for evacuation and alert messages, organized in 2 independent playlists
- Interface for connection to fire stations (ECI / CIE):
 - Activation inputs and global reset of the emergency
 - Zonal emergency activation inputs
 - Outputs of information on emergency status and system fault
 - RS485 / Modbus serial integration port
- 6 attenuator override outputs (24V override)

ONE Extended System Features:

- Connection of up to 10 ONE devices with redundant communication link

- Up to 60 zones
- ACSI port for connection of up to 8 microphones or fire panels, with access to each zone of the extended system
- Monitoring of the emergency system from any ONE unit
- Manual control of the evacuation system from any device or fire panel in the system
- Distribution of global audio sources, generated from the main unit:
 - System general audio sent from the MIX of the main unit to other units of the system
 - ACSI microphones and fire panels, both for public address messages and evacuation operations
- In addition to the integrated functions, each unit meets the mandatory requirements of the EN54 standard and has its own functions:
 - Exclusive and independent emergency messages
 - Emergency activation inputs per zone
 - Independent emergency power
 - For public address use, each unit has 1 audio input for music (Input 3) and 1 microphone input with priority (Input 1)
 - Input 2 receives the audio from the main unit and forwards it to the next unit

1.2 System diagram

The system will always consist of a main or master unit which will receive the connection of ACSI bus and its devices. Optionally, a system can be made up of more than one unit. In this case, the first unit must have a redundant system link card (ONE-LOOP) installed in its expansion bay. For more information on the connection of these types of systems and their configuration, see respectively section 2.2.11 and section 3.5.

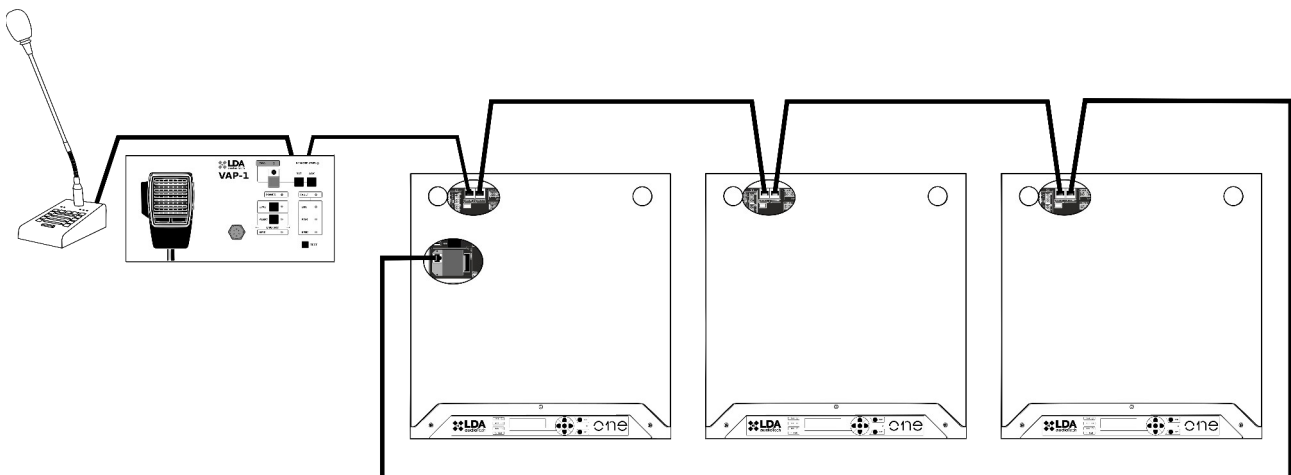

Figure 1: Example of a system with 3 units

1.3 HW and FW versions

For the operation of the expanded ONE system, ONE devices must have a serial number over 20xxxxxx and have their firmware updated to version v02.00.01.00 or higher. You can check for firmware updates on the LDA support website.

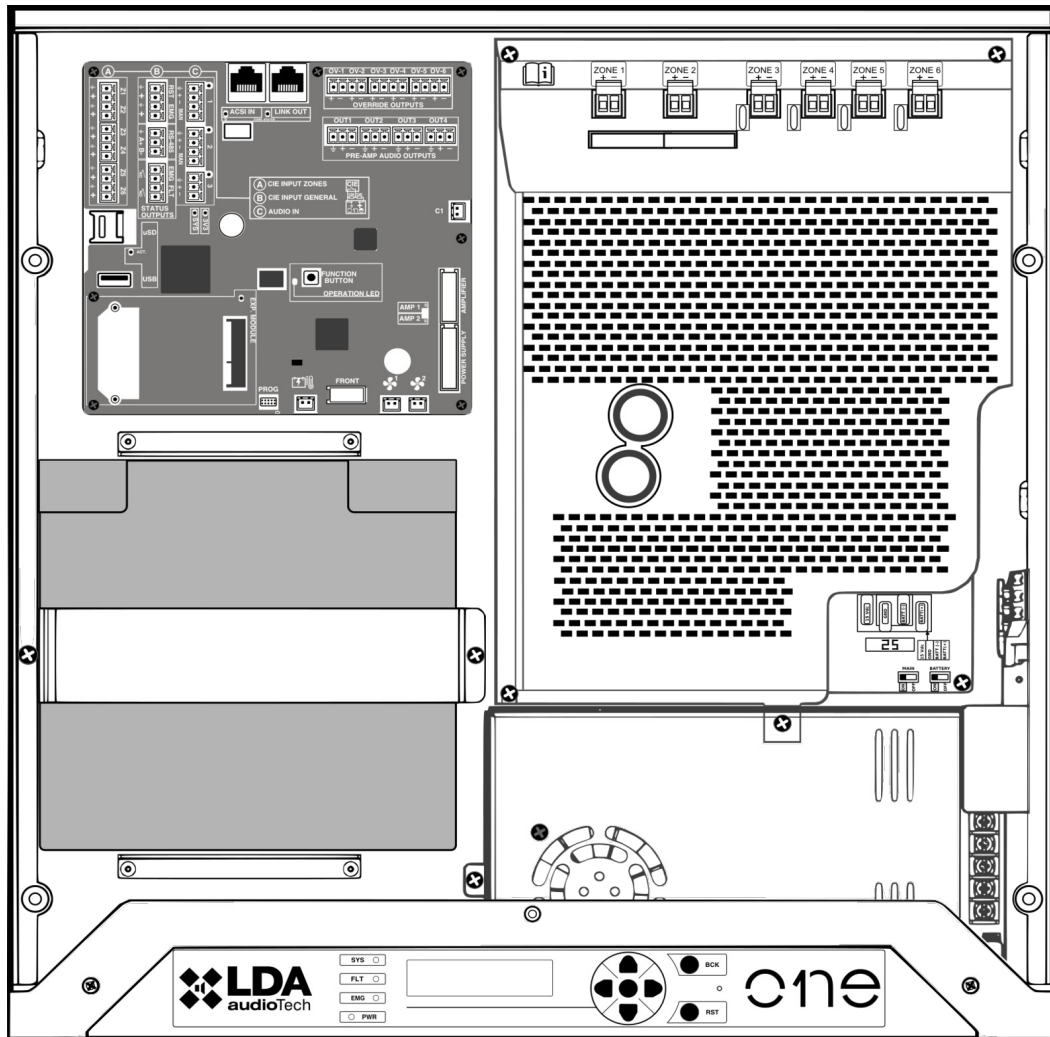

Figure 2: Inside view

1.4 User interface description

The device has a manual control interface, which will serve as an information and control point for the system user. A view of this element, which will be described in the following sections, is shown in figure 3.

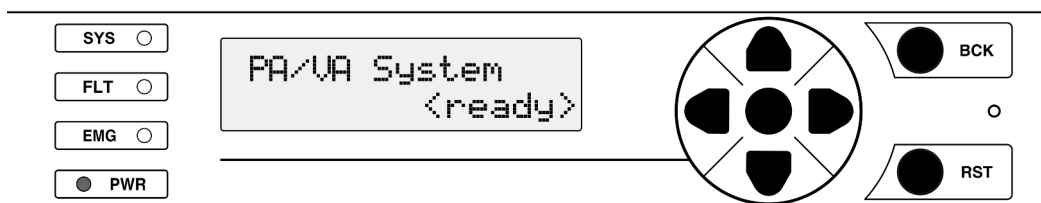

Figure 3: Control panel

1.4.1 Light indicators

The status indicators show the operating condition of the unit or system at all times. They are located on the left of the screen.

a) PWR: “POWER” / “ENERGÍA”. Green

On: when the device is powered from any of the possible power sources.

b) EMG: “EMERGENCY” / “EMERGENCIA”. Red

On: when the system is in an emergency operating status (voice alarm), either by manual or automatic activation from the CIE (Control and Indicating Equipment) from any of the available emergency inputs.

Along with the indicator lighting up, a continuous audible warning will be emitted. This warning can be silenced by the “BCK” button.

c) FLT: “FAULT” / “FALLO”. Amber

On: When the system is in a fault status. This indicator is automatically activated upon fault detection of any of the supervised functions.

Along with the indicator lighting up, an intermittent audible warning will be emitted. This announcement can be silenced by the “BACK” control, or automatically when the emergency microphone is used.

d) SYS: “SYSTEM FAULT” / “FALLO SISTEMA”. Amber

On: when there is a fault in the execution of the software of the unit, or in its memory. Reset the fault condition. If the problem persists, please see section 5.1.7.

1.4.2 Alphanumeric display

This screen, based on a 2-line, 16-character alphanumeric display, will serve to show the device configuration menus. Likewise, it will offer expanded information on the system that is not expressly included in the light indicators such as, among others, zonal statuses of emergency and fault.

1.4.3 Controls

a) Scrolling controls

They are located on the right of the display. They allow navigation through the use and configuration menus. The **central button** allows the **ENTER/OK** function, in order to access the menu and for operations requiring confirmation.

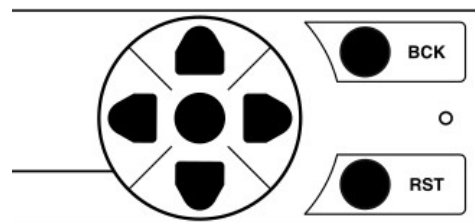

Figure 4: Interface buttons

b) Direct access controls

- i) ENTER/OK: Press for 2 seconds to perform the test of the indicators.
- ii) RESET/RST: Press for 2 seconds to allow the restart of the system operating condition, when it is in emergency or fault status.
- iii) BCK:
 - Menu navigation: go up one level / go back. If pressed for 3 seconds, the unit will return to the initial screen and restart the access level (log-out).
 - It silences the acoustic buzzer when it is playing (ACK function)

1.5 User profiles. Access level. Passwords

The access levels define the different user profiles that can operate with the unit / system. Each of the access levels has permission to enter different menu options, with level 1 having the smallest number of options available and level 5 having the largest number of options available.

Generally, access levels allow:

- Level 1 (L1): Visualization of elements according to EN54 and use of PA system¹
- Level 2 (L2): System management and emergency functions. Password²: **0002**
- Level 3 (L3): System configuration and advanced functions. Password²: **0003**
- Levels 4 and 5 (L4 and L5): Only accessible by the manufacturer.

In some screens, the access to some functions is allowed only to authorized level users. A user with a higher level password will be able to access lower level functions.

To access a certain level or to configure the access mode, use the Login menu (see section 3.4). You can select between access by confirmation, or access by 4-digit password.

The login has a validity time of 5 minutes, it can be reduced by pressing the BCK button for 2 seconds, then it will return to user level home screen 1.

1 PA Lock: A password access can be optionally configured for PA controls (volume, routing, etc.). See section 3.4.

2 This is your default password, which can be modified using the corresponding configuration menu (see section 3.4).

2 INSTALLATION INSTRUCTIONS

The device allows **wall** or **rack** installation in vertical or horizontal orientation, using optional installation accessories that facilitate the process.

Device **fixing** to the supports must be done from the **outside** of the device, removing 4 of the 8 screws located in the outer corners of the unit. For each pair of screws, remove the one closer to the front, where the support will be placed. Insert the clamping wings into the corresponding perforations, and place the screws that will fix the unit preventing it from falling.

2.1 Orientation change

To change the orientation, remove the 4 screws that fix the front of the device to the chassis, thus releasing the front. Now front orientation can be changed so that the controls are accessible according to their final placement.



Figure 5: Front fixing and interior view

2.2 Inputs and outputs

For wiring entry and exit, the enclosure has 7 pre-cut holes, which can easily be perforated with the help of a flat screwdriver. Its size is **36mm**, matching the size of the **32mm** tube fittings. For its correct installation, the wiring must be protected and properly fixed.

2.2.1 Power supply

Thanks to the battery charger, the device has a redundant power supply according to EN54-4. The AC input power supply range is universal **90-240 V~** with 50 or 60Hz frequency. The backup power supply source is an internal battery.

a) Mains main input, AC power

The power connection is made directly by internal wiring of the device, so it must include the mains bipolar **disconnection** elements externally. It is recommended to mark it with a label informing “evacuation system, do not disconnect”.

To handle the device, the external power must be disconnected.

There is a three-pole 1.5-2.5mm cable connector marked for Phase, Neutral and Ground. The cable can be inserted and removed thanks to the push button.

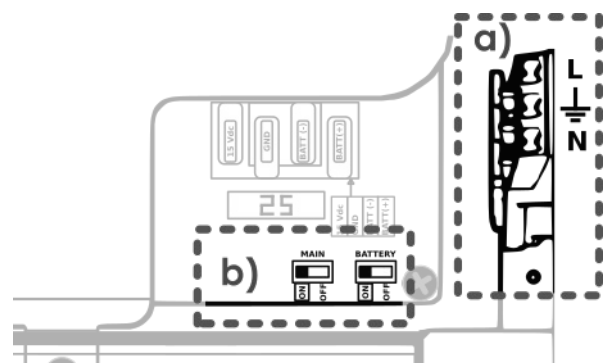

Figure 6: Power (mains & battery) connections

b) Disconnection switches

These switches cut the power path of the mains and the battery. These switches help to avoid the danger of sparks when connecting the battery, and they can serve to restart the device completely.

2.2.2 Battery installation

Before installing the battery, cut off the mains main power. It is also recommended to use the cut-off **switches** (image), this allows a safe mounting of the battery, preventing unintentional short circuits. Additionally, there is a 25 Amp safety fuse for the battery input located on the power supply board.

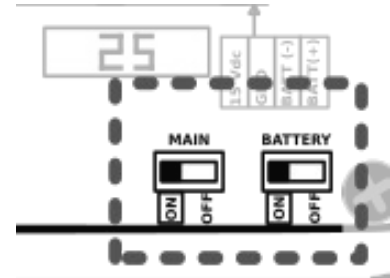

Figure 7: Power switches

The device has room for **12V** sealed lead-acid batteries with a **maximum size** of 167 (height) x181 (width) x76 (depth) mm.

The installed model must meet the corresponding battery standard:

For example, EN 60896-21/22 and EN 61056. In case of lead-regulated valve batteries, the device must be installed in a place with ventilation (<0.003 m³/h.)

Autonomy: The consumption per hour at rest is 0.4 Amps. Evacuation draw is 4 amps in 30 minutes. Ex: With the **YUASA NP17-12I** battery we have 17Ah to cover the reserve needs of 30 hours at rest + 30 minutes in evacuation.

Battery connection and fixing:

Unclip the fixing piece and release the flange that holds the cable for transport.

Once connected, place it in its position and screw the fixing piece.

NOTE: The battery should **never** be inverted once **installed**.

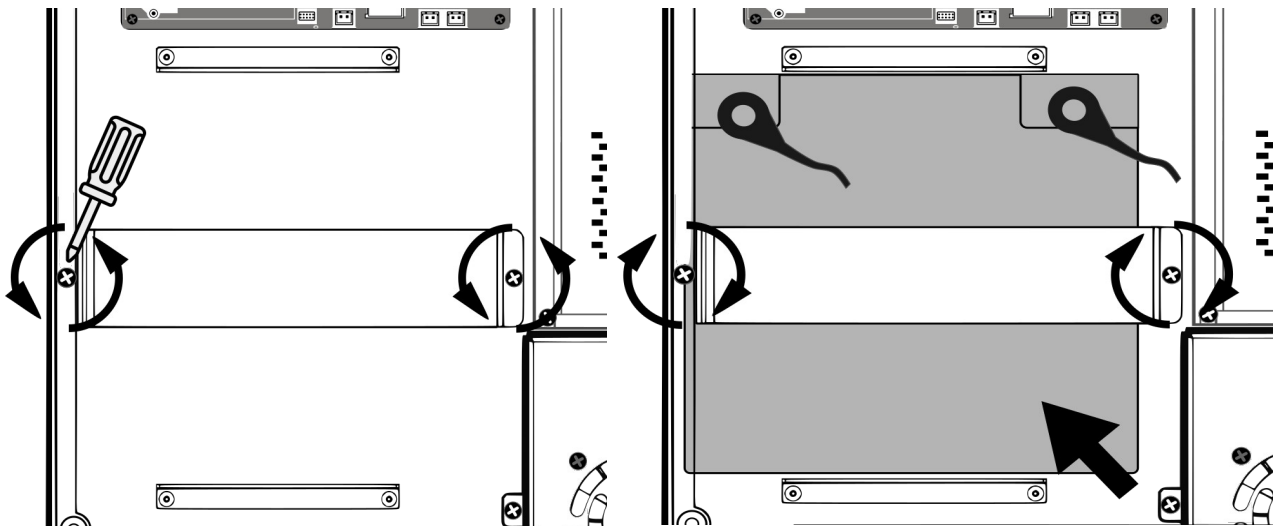

Figure 8: Battery installation

2.2.3 Fire Panel Interface

The emergency activation interface is advised for interfacing with fire control and indicating equipment (**ECI/CIE**). All input connections are supervised for faults in the transmission line. This interface is made up of four sections.

The connection is made using female euroblock connectors, supplied with the device. The cable section range for each pole of this connector is: 0.14 → 1.5mm² (30 → 14 AWG).

The inputs are activated upon detection of contact closure with the specified supervisory load. (**N.O.** = **normally open**). See chapter on manual configuration for other options and operating modes (section 3.3.7).

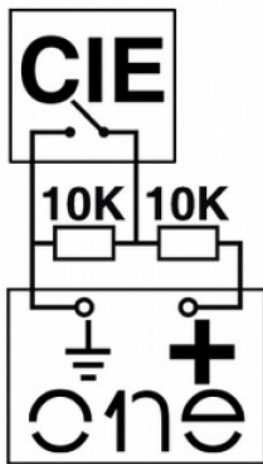

Figure 9: Connection to supervised ICE

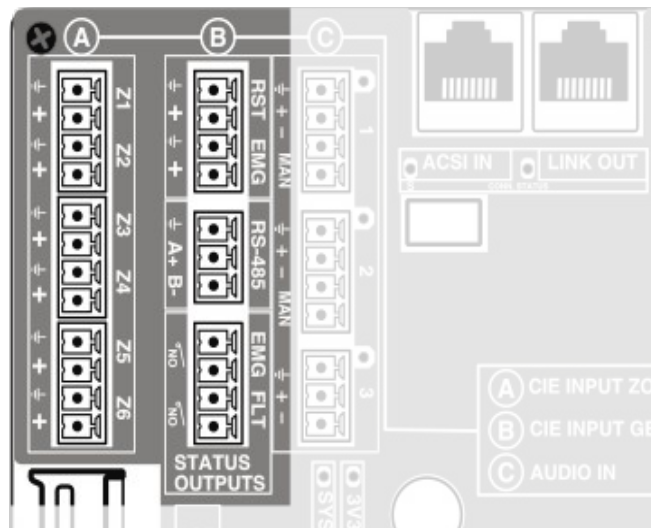

Figure 10: Fire Panel Interface

a) General emergency control inputs: RST and EMG

Supervised inputs for closing the connection of voltage-free contacts (**N.O.**): **Reset (RST)** and **Emergency (EMG)**.

In order to allow link supervision, the connection of the contact closure to the unit must be made by a shielded cable with two external 10KΩ resistors (supplied with the device) placed at the exit of the fire panel as indicated in figure 9.

Default operation: When the general emergency input (**EMG**) is activated by a contact closure (0V), the device will automatically change work mode, activating the emergency status, and emitting the voice evacuation message for each system zone. When the reset input (**RST**) is activated, the device will exit the emergency mode and return to the idle status (**PA**).

NOTE: When a system reset is made through the RST input, it will not be possible to return to emergency until a few seconds have passed.

b) Zonal emergency activation inputs (Z1 - Z6)

In order to allow link monitoring, these inputs are connected in the same way as the general inputs.

Default function: Activating the closing of a zone entrance Z1...Z6 will activate the general emergency status, and the list of evacuation messages in that zone(s) will be

played. Disactivating the closure will stop message playback, and a reset operation will be required to return to idle or PA mode.

c) Status outputs. EMG and FLT status outputs

Dry contacts intended for connection to fire panels or other external monitoring devices. They will indicate if the device is in emergency or fault respectively when they are closed. **(N.O.)**

They allow a maximum current of 350mA and a voltage of 350V.

d) RS-485 / MODBUS interface

Communication port on RS-485 half-duplex base for communication with the fire control panel. It needs to be connected by 2 twisted wires (A, B) plus a GND wire.

This port works with the MODBUS RTU protocol and allows the integration of the system with others, such as fire fighting panels. It is an advanced function of the device. To learn more, please consult the specific advanced manual, available on the LDA support website.

2.2.4 Speaker line outputs

The device has **6 powered outputs** for speaker lines. Each line connection has two terminals + and – for speakers connection to **100V** or **70V** speaker lines.

The total power of the device, **500W**, can be distributed to the zone outputs according to the installation design, without exceeding the maximum limit per each output: Zones 1 and 2 up to **500W**, Zones 3, 4, 5, 6 up to **120W**.

The loudspeaker lines can be supervised by measuring their impedance, thus allowing the detection of possible faults according to the EN54 standard. It must be taken into account that, for its correct supervision, the use of volume controllers should be avoided, and that each line should have an impedance within the measurement range (less than 600 Ohms).

The line measurement is carried out by default at a frequency of 19KHz. The use of **LDATFL2** line terminators is **recommended** in order to stabilize line conditions in this range and improve your monitoring results.

The lines must be connected to the device consecutively, from 1 onwards. Ex: If we use 4 lines, we will leave outputs 5 and 6 free.

The connection is made by a 2-pin female euroblock connector and a 5.08mm pitch (supplied with the device). The cable section range for each pole of this connector is: 0.5 → 2.5mm² (22 → 12 AWG).

NOTE: The output voltage up to 100V can be dangerous, therefore the correct **insulation** of the speaker lines must be ensured. Check that there are no short circuits, false contacts or ground leads in any of its wires with an impedance meter (remember that

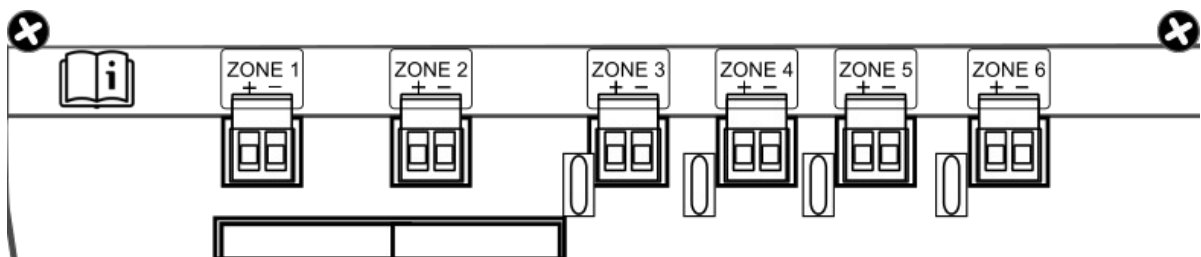

Figure 11: Speaker line outputs

conventional multimeters are not efficient). For more information, you can consult more specific documentation on impedance measurement on the LDA support website.

a) Backup amplifier:

ONE has two amplifiers and an amplification output matrix system, each of the 6 ONE outputs can have 3 different sources: amplifier 1 (audio 1), amplifier 2 (audio 2) and mute (without audio).

Each amplifier will reserve the other unit without the need for any additional configuration. However, as long as there are no problems, both will be available and it will be allowed to simultaneously have 2 audio sources in the device.

When an amplifier fault occurs (ex: Amp1), the system will automatically re-route the routing by assigning the remaining amp (ex: Amp2) to the highest priority audio source (e.g. evacuation message). In this way, it is guaranteed that the most important audio source will be prioritized when carrying out the matrixing process, and that it will have access to the available amplifier compared to other less important sources (eg: BGM background music). Zones that have lost the use of the amplifier will be muted.

NOTE: The source priority is preset in this order (from highest to lowest priority): evacuation microphones (VAP-1), evacuation message, alert message, PA microphone (MPS-8), priority audio inputs, non-priority audio input (BGM).

2.2.5 Audio source inputs

The system integrates **3 inputs** for background music and/or microphones. For further details, see the audio inputs configuration. At each input side there is an LED for the audio signal, which is activated with signal over -40dBV.

The audio input connection is made by euroblock connectors that allow cable sections between 0,14 → 1,5mm² (30 → 14 AWG). Input impedance 10Kohm.

a) Inputs 1 and 2

Inputs for background music or priority signal. They allow an activation trigger for each dry contact free of voltage or TTL signal to GND or by audio signal level, with configuration of routing to zones. Input level 1V RMS. Balanced audio.

b) Input 3

This input is configured as a background music input, because it does not have an activation trigger. Input level is 1 V RMS, balanced audio input.

c) Input 4. Internal mixer

The system has an input with no external connector, since it is a mixer integrated in the DSP, which uses a configurable combination of the 3 previous inputs.

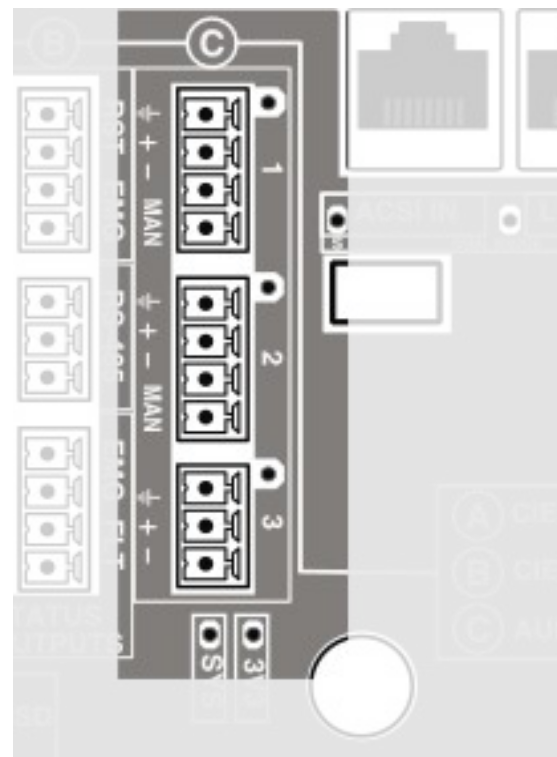

Figure 12: Audio source inputs

2.2.6 ACSI devices and microphones input

This input allows the connection of up to 8 compatible devices, such as **MPS-8** microphones or **VAP-1** emergency management panels.

The ACSI input integrates audio, communications and power, allowing emergency devices to be powered directly from the main or the backup source integrated in the device.

The connection is made using a screened **FTP** network cable **T568B**. The connection is made by bus, with a maximum connection length of **1000m**.

This input has an LED for audio tests and a status LED that will indicate that there are connected devices.

In expanded systems, with several ONE units, this input will change its functionality in the device(s) that does not occupy the first position, becoming a connection between the different ONE devices. This mode of operation is discussed in detail in section 2.2.11.

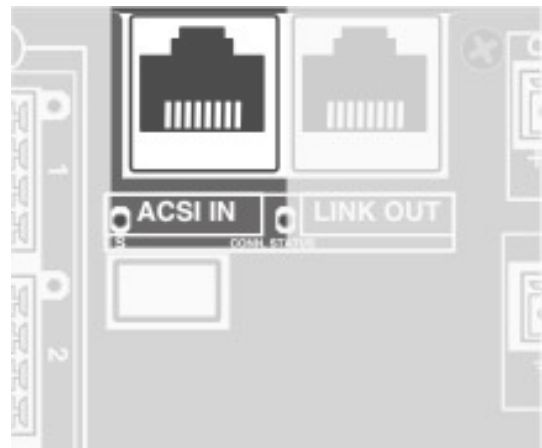

Figure 13: ACSI-IN port

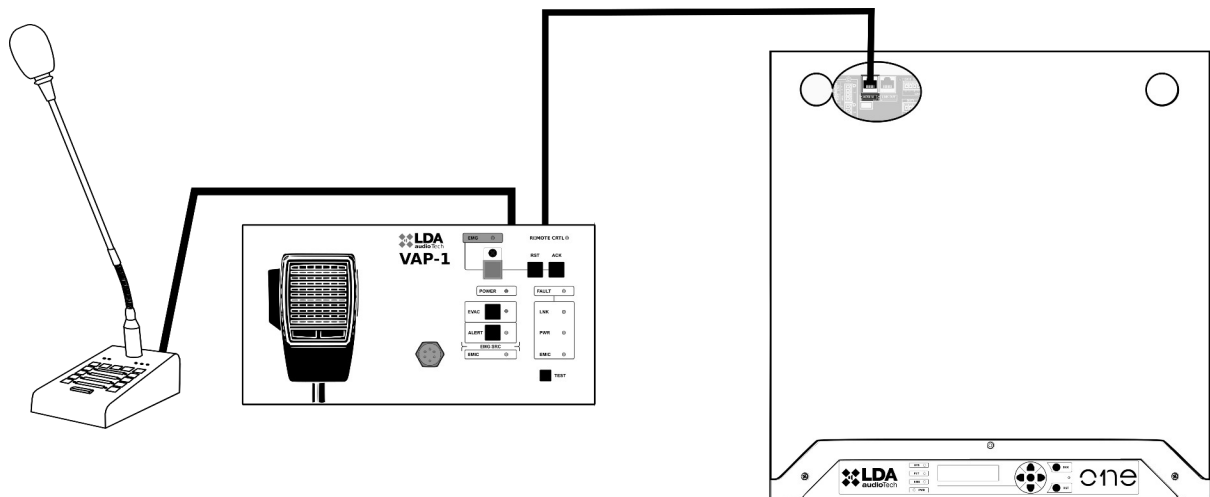

Figure 14: Example of ACSI devices connection

2.2.7 System expansion output. LINK-OUT

The LINK-OUT port provides the necessary interface for system expansion among various devices.

This connection embeds a serial communications bus for control data and 2 audio channels for the distribution of the global system sources, generated by the system main unit; all over the same cable.

The connection is made by a screened **FTP** network cable and standard **T568B**, with a maximum connection length of **200m** between the units.

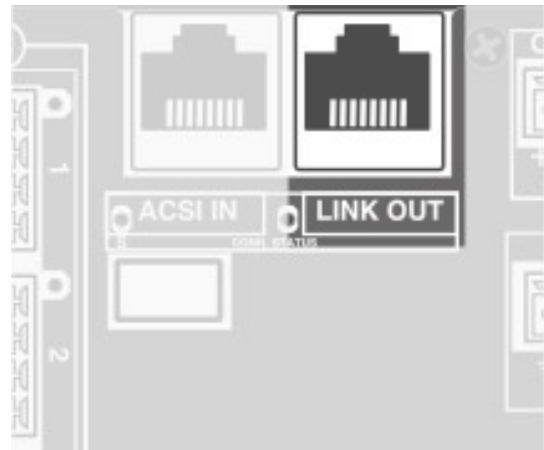

Figure 15: LINK-OUT port

2.2.8 Pre-amplified audio outputs. PRE-AMP OUTPUTS

There are **4 line level outputs** (1V RMS) for connection to external devices, such as backup amplifiers.

These outputs can be configured to obtain the same audio as the zones or as a recording output of the messages from the evacuation microphones.

Euroblock connectors (supplied with the device) with 3 contacts and 3.81mm pitch are used. The cable section range for each pole of this connector is: 0.14 → 1.5mm² (30 → 14 AWG). The maximum output load is 10 kOhm.

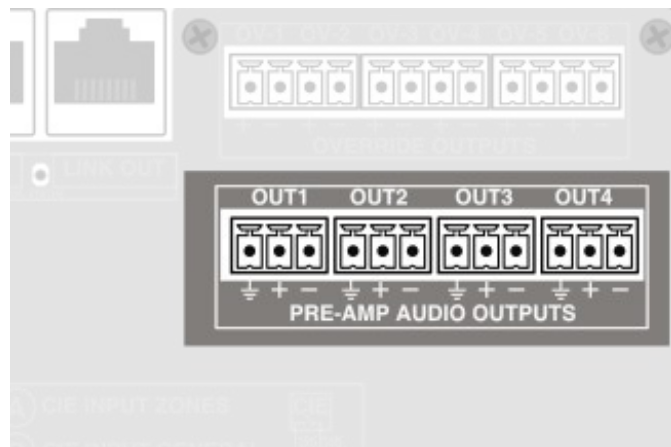

Figure 16: Preamplified outputs

2.2.9 Attenuators override output. OVERRIDE 24V

In the control board there are **6 attenuator override outputs** for public address lines. In idle status they have a voltage of 0V. In active status, each output has a voltage of **24V DC** and **20mA** of maximum current.

Connection is made using 2-contact euroblock female connectors and 3,81 mm pass (supplied with the device). Cable section range for each pole of this connector is: 0,14 → 1,5mm² (30 → 14 AWG).

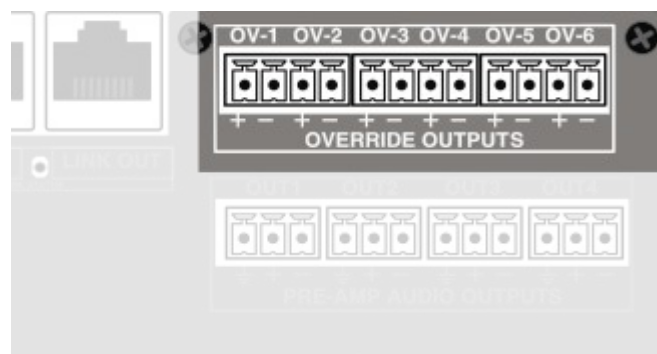

Figure 17: Override outputs

2.2.10 Internal connections

There are several connection ports for internal wiring, some should never be handled by the user.

a) Micro-SD card connector

This connection is used for software expansion, such as the installation of the EN54-4 battery charger.

b) USB

USB Type-A connector for external memory connection (MEMORY-STICK) allowing messages import, firmware update and import and export of configurations or Logs.

c) Expansion bay

Expansion bay for the connection of cards allowing the expansion of system functionality. For example, the ONE-LOOP accessory will be connected here, thus allowing the creation of distributed systems with several ONE units. Figure 19 shows how to install it in this bay.

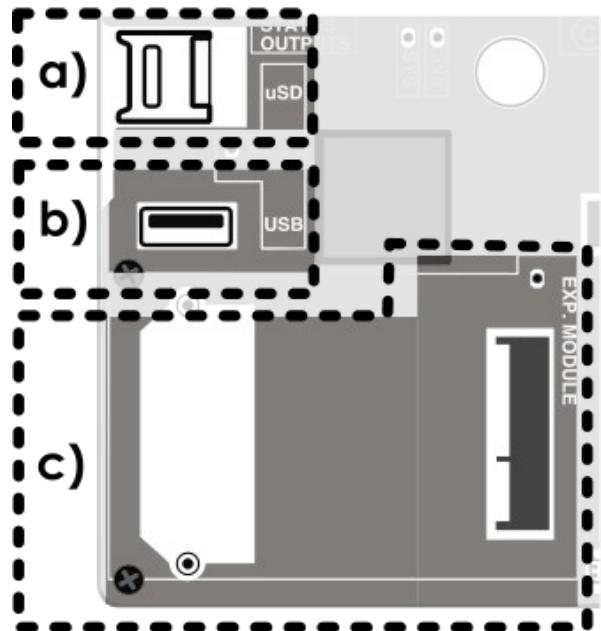

Figure 18: Further internal connections

2.2.11 Connecting distributed systems

There is the possibility of creating extended ONE systems made up of several units. This will require the installation of a **ONE-LOOP** card in the expansion bay of the first device, as shown in figure 19.

This card will have a double mission: to enable distributed system functions and to provide an additional port to make a return connection (LOOP) from the last computer on the network to the first one. The number of units that can be grouped in the same system will be limited by the ONE-LOOP card model installed, and they can reach a **maximum of 10 devices**.

The devices will be connected in a chain, so that each unit will have a physical connection with the previous and the next unit on the bus. The LINK-OUT port of each device must be connected to the ACSI-IN input of the

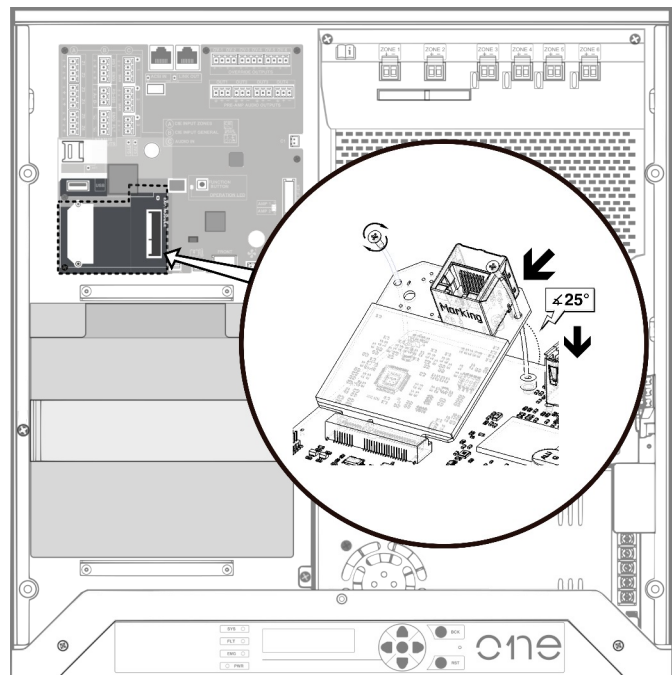

Figure 19: ONE-LOOP card installation

next one on the bus. This will be the case between all the units except the last one, where the connection will be made from its LINK-OUT port to the LOOP port that provides the expansion card of the first unit.

All these connections will be made using **shielded FTP network cable or category 5e (or greater) with standard T568B pinout**. The connection is made by bus, with a recommended length of 200 meters and a maximum of 800 meters between units.

NOTE: The sum of the distances between all the system devices never may be longer than 800 meters.

The order of placement of the units is important since, when setting up the system, the **numbers of the zones will be assigned consecutively**, starting with the main unit and counting the zones that each device has previously installed and configured.

Figure 20 shows an example of a system connection, consisting of 3 ONE devices. For more information on the configuration and use of this type of systems, please consult section 3.5 Multi-device distributed systems.

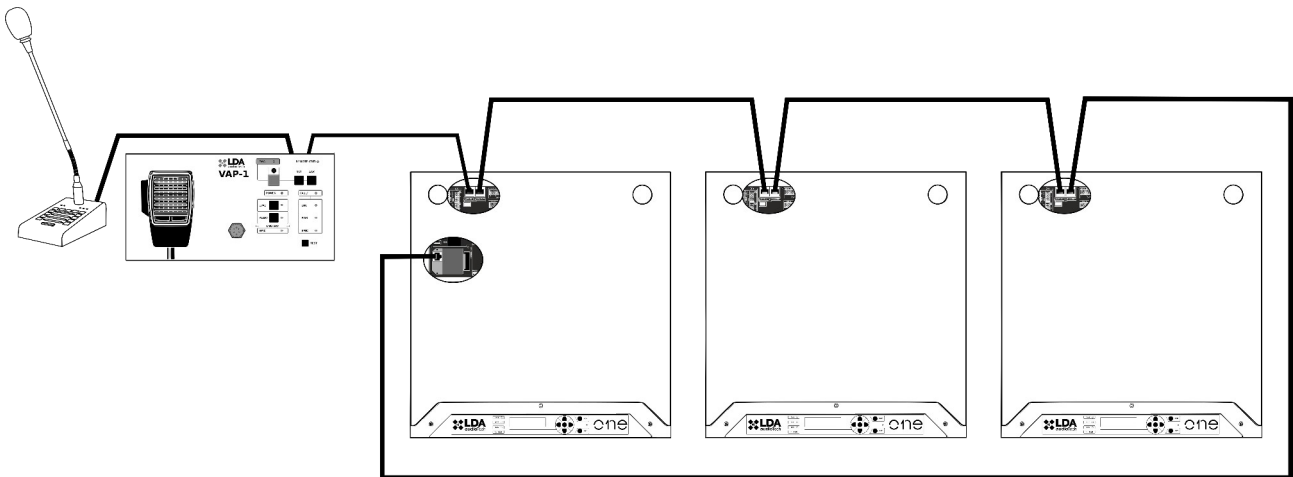

Figure 20: Example of a system with 3 units

NOTE: As shown in the picture, the bus master will be the only one that has its ACSI-IN port available to connect microphones and other ACSI compatible devices. The other units will use this port to receive the connection from the LINK-OUT output of the previous unit on the bus.

3 CONFIGURATION AND STARTUP

Once the needed connections are made, the elements and options used in the system should be configured.

3.1 Power supply

Before activating the power, first check the service switches that disable the AC and battery source inputs, see figure 3

Connect the device to the mains, it must turn on correctly. The front power LED lights up, during the startup the display will show the firmware version followed by the startup screen.

3.1.1 Battery charger installation

Before powering the device, the battery charger activation card must be installed, if available.

The **memory card** includes the battery charging software. It is installed in the micro SD card connector marked **(b)** in figure 18. Turning on the unit, the option will be automatically loaded, and the option to activate the charger and the battery monitoring will appear in the manual configuration menu (see section 3.3.8).

3.1.2 Device closure

Once the battery and the internal connections are installed, **close** and screw the device **cover** to make the configuration.

3.2 Automatic Configuration. <Run Autoseup>

The automatic setup feature saves much of the setup work of setting up an ONE system. Any configuration can be edited later manually. It is launched by pressing the OK button on the "Run AutoSetup" option in the **Configuration** → **Device** → **Run AutoSetup** menu.

The autoseup process verifies the installed elements according to the requirements of the EN54 standard by following these on-screen steps.

3.2.1 Date and time.

The configured date is checked. If it is previous to 2010, it will ask the user to adjust it manually.

3.2.2 Evacuation messages.

When the insertion of a USB memory in the unit is detected, the user will be asked if he desires to import pre-recorded messages from the USB memory. In this case, the user will also be asked if he wants to delete the messages already stored in the unit. See section 3.3.5 for details about the messages import process and the requirements that these must meet in order to be copied to the unit.

LDA offers a free audio file conversion tool on its support website.

Once the messages are loaded, the user will be asked to **close the cover** of the unit in order to calibrate the speaker and amplifier lines.

3.2.3 Advanced mode selection

By activating the advanced mode, the user will be asked if he wants to configure the speaker line outputs in A + B mode. The following sections explain the process that the unit will perform automatically.

a) Speaker lines and zones.

The device checks the loudspeaker lines to detect those which have been installed. Speaker lines must be connected in order from 1 to 6, since when the unit detects a line without load or with an impedance above the measurement range (**600 Ohms**), the unit deduces that neither this line nor the following ones are installed.

To avoid this problem, an **LDATFL2** line terminator must be installed, so that the unit recognizes it as a line in use. That way, all the detected zones will be configured with active line supervision, this can be adjusted from the **Configuration -> Speaker Lines** menu.

Furthermore, when the A+B mode has been selected, it must be taken into account that each zone must have 2 valid consecutive A and B lines. For example, zone 1 would be formed by lines 1 and 2, zone 2 by lines 3 and 4, and zone 3 by lines 5 and 6. In case of detecting an odd number, the extra lines will remain unassigned to any zone.

NOTE: Volume control cannot be used with active line supervision, as the line impedance varies according to the set level and would indicate a fault.

NOTE: The impedance values are measured by default at 19kHz. They will be different from those measured with a manual impedance meter that generally measures at 1kHz.

b) CIE (Control and Indicating Equipment) interface

It checks that the inputs are connected and have terminators as specified in "Connections" section 2.2.3. In each detected input, the supervision of the link will be activated.

c) Battery

Battery management depends on the installation of the charger accessory EN54-4. The system checks if the **memory card** is installed with the **charger** module. In this case, the system detects that a battery is installed, checking voltage and internal impedance. The minimum working voltage is **10.5V** with a maximum impedance of **200 mOhms**. For more accurate monitoring, it is recommended to reset the battery nominal impedance according to the installed battery once it is 100% charged (see configuration "Fault Levels" in section 3.3.8).

d) ACSI devices

ACSI devices connected to the unit before the autoseup process will be automatically **installed**. In this way, these devices will be monitored, and a fault indication will appear from now on, if the connection with any of them is faulty.

If any detection problem occurs, it is recommended to check that the **address** of each device is correctly configured, that there are no conflicts between them, and that the bus terminator of the last device is active.

e) Backup amplifier

The backup amplifier and the supervision of amplifiers are **automatically activated**. The unit will flag a fault if any of them stops working at any time, or if it does not offer the appropriate level of gain.

f) Setup Report

At the end of the process, the number of detected zones and lines and the number of installed ACSI devices are displayed on the screen. It is important to check that this matches the expectations, otherwise you will have to do a manual configuration or solve potential problems carrying out a new autoseup process.

3.3 Manual configuration. <Configuration>

This menu allows the installer user to manually adjust system parameters and perform advanced diagnostics.

3.3.1 Audio Inputs. <Audio Inputs>

a) Inputs 1 and 2 configuration

- **Vumeter:** Input audio level indicator. (from -100 to 0dBV)
- **PA Volume:** Volume adjustment in PA mode. (-100 a +12dB)
- **VA Volume:** Volume adjustment in evacuation mode from -100 to 12dB. It is activated when the system is in an emergency status.
- **Mute:** It mutes the input.
- **Eq. Enable, Eq Settings:** These controls allow you to activate and configure the input parametric equalizer.
- **Compressor:** It activates a compressor expander to improve input dynamic range.
- **Override 24V:** When a priority input is activated, it turns on the override outputs of the zones where it is routed.
- **Trigger Mode:** These inputs can be configured with 3 trigger modes. TTL maneuver to close contacts that are normally open, noise gate (VOX) or always active (always on). The maneuver or trigger will allow input activation of an audio source without user intervention. Their intended use is for temporary sources, such as microphones, warning systems, etc.
 - **Always ON:** Always active input, note that in "Always on" mode the source with the highest priority will occupy all the areas where this is selected.
 - **TTL Contact:** It enables or disables the TTL input to close normally open contact.
 - **VOX Enabled:** It enables the signal activation system by level called VOX.
 - **VOX Threshold:** It adjusts the noise gate signal level for noise gate activated operation.
- **Label:** It allows you to customize a name for this input.

b) Input 3. Input 3

Input intended for background music. The menu includes the same functions as sources 1 and 2, except for the parameters that configure the activation mode ("Trigger Mode" submenu).

c) Mixer input, Input 4 - MIX.

The mixer is a tool allowing you to work with priority sources, such as microphones, without cutting the background music.

Like inputs 1 and 2, it allows the use of 24V Override, level adjustment, etc. The specific settings are:

- **Inputs Select:** It selects which physical sources (1 through 3) can enter the mixer.
- **Inputs Volume:** It adjusts the input level of each source to the mixer.
- **Mix Fade:** It configures the attenuation of lower priority sources when a priority source is activated. Ex: Speaking into a microphone connected to Input 2, you want the music connected to Input 3 to drop -15 dB.

Sources priority highest to lowest: Input 1, Input 2, Input 4 MIX, Input 3.

3.3.2 Audio Outputs.

<Audio Outputs>

In this menu amplifier outputs and preamplifier outputs are configured.

a) Amplifier

The amplifier output manages the main amp and the backup amp simultaneously.

- **Master PA Vol, Master VA Vol:** It sets the overall unit working volume levels in PA and VA. These volumes will apply to all zones.
- **Mute:** It controls Mute of all the unit outputs.
- **Eq Enable and Eq Settings:** It allows activating and configuring the parametric equalizer.
- **Loudness.** It activates the automatic isophonic equalization system adapted to human ear. This system improves sound perception when the volume is low.
- **Advanced:** Amplifier advanced configuration parameters:
 - **Amplifier N.** It allows activating or deactivating the amplifier **supervision** and displaying **gain** (19kHz/39dB +/-1dB) and **temperature**.
 - **Common config.** It allows setting **fault detection** parameters as well as **70V** lines mode parameters.

b) Pre-Outputs

The preamp outputs can be used for **external amplifiers** for zone amplification reinforcement or emergency warning recorder. Each output has its independent volume adjustment.

- **PA Volume, VA Volume:** It sets PA and VA volume levels of the selected preamp output.
- **Mute:** It controls Mute of the selected output.
- **Link to zone.** It sets the zone to which it is linked, in order to receive the same audio of that zone.

c) **VA Rec-Out:** This control allows activating the “recording output” or “rec-out” mode. When active, pre-out output 4 will no longer be linked to a zone and will instead play live voice messages broadcast to the evacuating zones. (Ex: Manual messages in VAP-1 panels)

3.3.3 Speaker Lines configuration. <Speaker Lines>

For each speaker line you can individually configure its label and line supervision parameters.

- **Supervision:** It enables or disables line/zone supervision
- **Line Status:** It indicates if the status is correct or faulty. Possible status are:
 - **Sup. Off.** Supervision deactivated
 - **Earth Fault.** Leakage fault in speaker line
 - **Calibr. Error.** Error trying to calibrate the line.
 - **Invalid M.** Measurement out of HW range (5-800 Ohms).
 - **Open C.** Open circuit or deviation on calibrated impedance.
 - **Short C.** Short circuit or deviation on calibrated impedance.
 - **OK.** Correct line, within tolerance ranges.
- **LastMeas Z:** It reports the impedance value of the last measurement.
- **Nominal Z:** It is the impedance value saved at the time of the calibration.
- **Nominal Z mute:** Impedance value calibrated by the measurement system in Mute. (The two values may slightly differ, due to the use of two independent measurement systems)
- **Calibrate:** It starts a new calibration of the line. **NOTE:** It should only be done when you are sure that the line is correct. The device has a maximum measurement limit (600 Ohms); when the impedance exceeds that limit, it will show 9999. In this case, a line terminator must be used.
- **Lower Tol% and Upper Tol%:** The limits of variation allowed in percentage with respect to the calibrated impedance. Outside these margins, the system indicates an open or a short circuit.
- **Owner Zone:** Number of the zone to which the line belongs.
- **Owner Z. Label:** Label of the zone to which the line belongs.

3.3.4 Configuration of device zones. <Device Zones>

a) Zones Config

- **Zone X Mute:** It mutes the audio of the selected zone.
- **Zone X Label:** It allows you to see and edit the label of the selected area

b) A/B mode

It activates A / B mode in all zones of the device. In this way, each zone has 2 speaker lines assigned, so the system will have 3 zones. This mode is simultaneously activated for **all** zones. Thanks to this mode, the loss of a loudspeaker line (A) due to a fault will not prevent the zone from continuing to operate on line B.

NOTA (1): The assignment of lines to zones will always be consecutive, so that lines 1 and 2 would belong to zone 1, lines 3 and 4 to zone 2, and 5 and 6 to zone 3.

NOTA (2): This parameter will be locked when the device belongs to a distributed system with more than one ONE device. To edit it, you must previously unlink the device from the system (see section 3.5).

c) Zones Number

Number of zones of the unit. It allows you to configure the number to the zones that are actually being used.

NOTA: This parameter will be locked when the device belongs to a distributed system with more than one ONE device. To edit it, you must previously unlink the device from the system (see section 3.5).

3.3.5 Import and edit messages. <Messages>

The system has these options for editing evacuation and alert messages. To convert the messages to the correct format, use the **LDA Audio Converter** utility, which can be downloaded from the LDA support website.

The ONE device allows you to play multiple messages spread across **2** playlists. These are called “Evac and Alert” and will be respectively reproduced with the launch of alert or evacuation messages.

- **Storage:**

- **View Playlists:** It allows you to consult the files included in each playlist and the order in which they will be played. It also enables you to individually delete messages.
- **Import MSG:** Option to import messages from a USB memory to the unit. The user will be asked to indicate which DATAxx folder number of the USB is to be used as the source. Folders from DATA01 to DATA99 can be used as the source. USB Flash Drive Information and Requirements:
 - The USB memory must be formatted in **FAT32** file system format.
 - Location “DATAxx \EVAC\” in the root directory/folder of the USB memory for evacuation messages. Ex: F:\DATA01\EVAC
 - Location “DATAxx \ALERT\” on the USB for alert messages.
 - The files must be in **WAV PCM mono** format, with **16 or 24 bit** resolution and a sampling rate of **48kHz**.
 - File **names** must have a **maximum of 8** characters with no spaces or special characters (symbols) with the extension “.wav”.

Messages import will work as follows:

- The device screen will show a progress bar during the process.
- If, when importing a message, another message with the same name already existed in the memory of the unit, **it will be overwritten**.
- After the import process, the playlist will be reordered in **alphabetical order**.
- At the end of the process, the device screen **will show a summary** indicating the import result for all the files that have been detected in the DATAxx folder of the USB memory.
- **Backup MSG:** It is possible to make a copy of the messages currently installed on the device to a USB memory. As in the import process, the user will be asked which folder DATAxx he wants to use, choosing between 01 and 99. The USB

drive must be formatted in the FAT32 file system format. The evacuation and alert message files will be stored in the folders “\DATAxx\EVAC\” and “\DATAxx\ALERT\” respectively.

- **Erase MSG:** It allows you to **erase** all messages from the device internal memory.
- **Disk Usage.** It shows the number of messages in each list and the available memory. Disk full size is 64944 KB.
- **Player Slot N:** Configuration of message players 1 and 2. Player 1 will be used for evacuation messages, and player 2 for alert messages. Following parameters can be viewed/configured:
 - **Vumeter:** Real-time view of the audio level generated by the selected message player.
 - **VA Volume:** The volume level that the message player will have at emergency mode.
 - **Eq. Enable, Eq. Settings:** It allows activation and adjustment of each player parametric equalizer.

3.3.6 PA/VA microphones. ACSI devices

In order to customize the configuration and monitor the ACSI devices, they must be **installed** in the system beforehand, either through the **AutoSetup** process or manually using the **/Configuration/ACSI Devices/Install** menu.

They are installed indicating in each address of the bus which device model is to be connected. The devices installed in the system will be monitored, and a fault will be reported if they are disconnected. Addresses that are not to be used should be left configured as “<none>”.

Devices priority will depend on their address on the bus and on the type of device. Address 1 will have the highest priority. VAP emergency microphones have higher priority than MPS microphones regardless of their address.

- **Monitor:** It shows complete information for each bus address, indicating the device that is currently connected, the one that is installed and the status
- **Install:** It allows you to install the ACSI devices for its supervision, choosing in each address of the bus which model we want to install.
- **Input Config:** It adjusts the audio parameters **common** to the ACSI bus.
 - **Vumeter:** Real-time display of the audio signal level being received by the ACSI input.
 - **Eq. Enable, Eq. Settings:** It enables and configures the 3-band parametric equalizer assigned to the ACSI audio input.
 - **Compressor:** It activates a compressor expander to improve the dynamic range of the ACSI input.
- **MICs Config:** Custom settings for installed microphones:
 - **Vumeter:** It indicates the signal level of the ACSI input. (only take into account when the device is active)
 - **Volume:** Input level adjustment tuner from -100 to + 12dB of each installed device.
 - **Override 24V:** It sets up the activation of override outputs for PA microphones. In VA, the exits of the emergency zones are always activated.

- **Label:** It allows you to edit a label for this device.

3.3.7 Interface with the fire panel. <CIE>

It allows the configuration of the contact closure inputs as well as the activation and configuration of the RS-485 MODBUS bus, for operatives with integrated fire control panels.

- **Input Status:** It displays the status of each input.
- **Inputs Config:** It configures the activation and supervision of each independent input.
 - **Enable:** It activates or deactivates the input.
In case of EMG (EMG Mode) dry contact, also this options are editable:
 - **Evac All:** Launch EVAC message at all zones when activates. Default value.
 - **Alert All:** Launch ALERT message at all zones when activates.
 - **Set Sys EMG:** Sets the EMG mode at the system, but launches no message.
 - **Supervision:** It activates input monitoring. See section 2.2.3 Fire Panel Interface .
 - **N/C Mode:** It changes the input activation polarity. If enabled, it will work in N/C mode (normally closed), otherwise it will work in N/O mode (normally open).
In case of Zx dry contact, the following options are also editable
 - **Alert-mode:** The Zx input will activate alert mode, instead of evacuation mode, in the linked zone.
 - **Zone Id:** It assigns the zone affected by the Zx input.
- **CIE Auto-Alert:** It activates the automatic reproduction of the alert message in the other zones, when any zone is evacuated from the CIE.
- **CIE Auto-Reset:** When this parameter is active, the system will exit emergency when releasing the input closure that activated it.
- **CIE Local Mode:** By activating this mode, the general control inputs EMG and RST will only act on the zones of that unit, but not on the entire system. This option is particularly useful in distributed multi-device systems, to better segment the use of general ECI interfaces.

NOTE: Opposite to CIE Local Mode, CIE Global Mode is the default value, reason why there are no explicit activation item. This modality makes EMG and RST dry contacts impact to the entire system.

- **Status OUT N/C:** It inverts the polarity of the FLT and EMG output signals, switching to N/ C mode (normally closed).
- **RS485 Conf.** It configures the parameters of the RS485 communication port.
 - **Baud Rate:** Transmission speed
 - **Parity:** Parity mode of serial communications
 - **Stop Bits:** Stop bits to be used in serial communications

3.3.8 Battery Charger. <Battery>

These options are only available if the **charger** accessory is **installed**.

The battery charger manages charging, activation, discharge and monitoring of a 12V lead acid battery.

- **Monitor:** In this section we can see information about the battery and the charger: status, impedance, voltage, charging current and temperature.
- **Charger Enable:** It enables/disables the battery charger. The charging current is 2 Amps.
- **Supervision:** It enables the monitoring of battery status and fault detection. Only when the charger is enabled. Voltage monitoring is performed every minute, and impedance monitoring is done every 10 minutes.
- **Temp Sensor:** It enables the monitoring of the battery temperature sensor. It is checked every minute.
- **Faults Levels:** The minimum battery voltage and maximum impedance can be adjusted. Factory settings are 10.5V and 200mOhms. It is recommended to **set** the maximum impedance value to 40% above the value measured with the new and charged battery to ensure its autonomy. Ex: 50 mOhms for YUASA NP17-12I battery.

a) Battery charger operation and monitoring. ONE-BC

The monitor menu is available to assist the user in **diagnosing** the **battery status**.

- **Voltage:** It indicates the current battery voltage.
- **Impedance:** Value obtained from the impedance measurement of the battery.
- **Chg status:** Battery charger status. It indicates the current status of the load:
 - **Disabled:** Battery charger disabled.
 - **Bulk:** Phase of maximum load intensity where it is possible to reach 80% of the load in the shortest time, it has a limit of 24 hours. If it does not manage to finish this stage, it will indicate "Chg timeout" fault.
 - **Absorption:** In this phase, the charge current decreases progressively until the battery achieves 100% charge. It also has a 24h time limit according to regulations.
 - **Float:** The battery is fully charged and this is the condition to keep it 100% charged. Generally, the voltage will be between 13 and 13.8V.
- **Current:** It indicates the charged current at the moment.
- **Temperature:** Temperature value of the battery sensor in Celsius degrees.

3.3.9 Save and charge configuration. <Load/Save>

Device configuration can be saved or loaded.

- **Export Dev CFG:** It sends a copy of the device configuration to the USB memory. By selecting the number, the parameters will be saved in the \DATAxx folder. If there is a previous configuration, the system will overwrite previous data.
- **Import Dev CFG:** It imports the device configuration data from the selected DATAxx folder from the USB memory.

NOTE: When exporting/importing a device configuration, all the device data are included, along with its user management (passwords and authorization for each level of access). Therefore, you must be sure to know these data before importing any configuration from a USB memory.

3.3.10 Device Configuration. <Device>

General parameter configuration of the device:

- **Run AutoSetup:** It launches the device automatic configuration, according to EN54. See details in 3.2 Automatic Configuration. <Run Autosetup>
- **Restart Device:** It restarts the unit as well as the internal processors.
- **Factory Reset:** It restores device **Factory settings**. It deletes **all** the parameters configured by the user, except logs and pre-recorded messages. If the device belongs to an expanded system, it will be disconnected from it.
- **FW_Update:** It allows to update the firmware version through a file saved on a USB memory connected. You can find the latest firmware version on the LDA support website. **NOTE:** The file must be in the root directory and be named as **fw.bin** or **update.bin**. The USB memory stick must be formatted in **FAT32** files system format.
- **Location:** It allows modifying a textual label that describes device location or name. This information can be made visible on the home screen by activating the “*Show on Home*” option available in this menu.

3.3.11 System configuration. <System>

This category includes the options to configure the system.

- **Run Discover:** It executes the Discover operation that will constitute a new distributed system of several ONE units. This operation will only be allowed if the device launching this operation has a ONE-LOOP card installed. For more details, consult section 3.5.
- **System Info:** This screen shows information on the current system linked to the device being accessed. It contains the following information:
 - **Device Addr:** Device address on the bus (from 1 to 10).
 - **Sys Zone Count:** Number of zones in the system (between 1 and 60).
 - **Sys Dev Count:** Number of devices constituting the system (between 1 and 10).
 - **System UID:** Unique identifier of the system to which the unit is linked.
- **Device Monitor:** This screen shows information and status of each of the units that are part of the system, either the local unit from which you are accessing or a remote unit. You must choose the address you want to consult, and then you can access the following information:
 - **Dev x Link:** Device link status with address x.
 - **Dev x Zones:** Number of zones managed by device with address x.
 - **Dev x First Z:** Identifier of the first zone of the device with address x.
 - **Identify x:** It launches an identification of the selected unit, which will activate its indicators for a few seconds, thus allowing the user to physically identify which unit it is.

- **Local Config:** Device local settings. It contains the following options:
 - **Bus Baudrate:** Transmission speed for the serial bus that is established between each unit. It is important that this value is the same between all the units of the system, otherwise there will be communication and connection problems between the units.
 - **Loopback FLT:** It establishes the supervision of the return link (from the last unit to the first one in the network). If this option is disabled, the system will stop monitoring this link, and it will not flag a fault if it is not operating.
 - **Slave beep on:** When this option is activated, the unit will emit audible warnings when it is a “slave” in the system. Not activating this option, “slave” warnings issuing will be blocked, and the master will be in charge of performing this function.
 - **Unlink:** When executing this operation, the accessed unit will be unlinked from the system to which it currently belongs.
- **Date/Time:** Feature to check and modify the date and time configured for the system.

3.4 User management <Login>

This menu category is intended to manage the access control of the different users of the unit. In this menu you can find these two sections:

- **Insert Login:** The user can be logged in with the password corresponding to his access level. However, when browsing the rest of the menus, a password access will be requested automatically on those screens that require it.
- **Access Config:** In this section you can customize each level password. You can enable a **password** for PA management (L1) and modify or disable passwords for **L2** and **L3** access levels.

3.5 Multi-device distributed systems

3.5.1 Introduction

Originally, each ONE unit represents itself as a system of up to 6 zones. In order to undertake larger installations, there is the possibility of expanding the system by grouping together several ONE units that are conveniently connected and configured.

The ability to form these distributed systems is enabled by installing a ONE-LOOP card in the expansion bay of the **first** unit, which will act as the **bus master**. The installed card model will establish the limit of devices that can be connected, being able to reach a maximum of 10.

The specific aspects of the system wiring and the ONE-LOOP card installation have been detailed in section 2.2.11 Connecting distributed systems.

3.5.2 Individual configuration of each unit

The system will be constituted as the grouping of each one of the units that compose it. These units must be **previously configured** separately, as if they were independent systems by themselves.

The individual configuration of each unit can be achieved in two ways, the simplest will be by running the **autosetup** process where the unit will detect the connected lines,

battery, etc. (see section 3.2). The other option is a manual configuration that must include, among others, the following operations:

- Loading prerecorded messages
- Speaker line and number of zones configuration
- ICE interface configuration with fire panel
- Battery charger configuration
- Configuration of sources, volumes and local matrix
- ACSI Device Configuration (only for Master unit)

3.5.3 System setup - Discover operation

Once the unit has been properly wired (see section 2.2.11) and each unit has been configured separately, it is time to create the new distributed system. This can be achieved by executing the Discover action from the system master. This option is available in the /Configuration/System menu.

After the Discover process, each unit will display an overview message indicating the number of units and zones that have been detected and that will constitute the new system.

3.5.4 Distributed system operation

a) Zones

The new system will group all the zones included in each unit. The zones will be ordered under a new nomenclature using common indexing. Thus, if for example we connect 3 units with 2 zones each, there will be a total of 6 zones in the system. The identifiers of the zones would look like this:

- Device 1: zones 1 and 2
- Device 2: zones 3 and 4
- Device 3: zones 5 and 6

b) Audio sources

Each unit will continue to maintain the normal operation of its matrix of audio sources (see section 4.3.2). The only exception will be that, in the "slave" unit, **the Input 2 source will be disabled and nothing should be wired to this connector.**

Instead, Input 2 of these devices will be replaced by the global system source, which corresponds to Input4-MIX of the master device. This means that, using the Input 2 matrix of each slave, you will be able to select which of its zones will receive the global audio source and which will not.

The Input 1, Input 3 and Input 4-MIX sources of each unit will continue to function as before, allowing their **use for local audio sources**, which can only be routed to the zones of that same unit.

c) ACSI microphones

It has already been seen that the only device that will have its ACSI port available will be the master of the network. However, the microphones connected to this bus will work globally with the entire system. This means that they can act on any of the zones, regardless of the unit that they belong to.

This is possible thanks to the unified global nomenclature of the zones, which has been described in section a).

d) VA control

Control of the emergency in a distributed system will be similar to that of a single-unit system, having the same operations already described in section 4.2. However, it is important to draw attention to certain details:

- **System emergency status:** The system will have a unified emergency status, and there will be no units in VA or in PA. This means that, in order to evacuate zone X of any of the units, all units will activate their emergency status. This also affects the RESET operation, which will reset the emergency status of the entire system (and units and zones members), executed from any of the ONE units;
- **Distributed control:** Each unit of a distributed system will act as an **external control interface for the other units**. From the screen of any of these units, it will be possible to control and monitor the status of any zone of the system, either its own or that of others. This also applies to ACSI emergency panels (VAP-1) that will be able to act on all zones, and to connection interfaces for fire stations (ECI/CIE). The control that this type of switchboards performs on each device is distributed to the rest of the system, so an appropriate configuration must be used to avoid the generation of contradictory orders that could cause undesired operations.
- **Local evacuation and warning messages:** each unit in the system has its own player and its own message memory. Therefore, each zone of the system will be evacuated or alerted with the messages that its “parent” unit has configured. This gives the system the ability to customize the evacuation and alert messages that each unit will emit through its zones. In case you do not want to differentiate the messages between the areas, it will be enough to install the same messages on all network units.

3.6 Advanced configuration

3.6.1 Advanced configuration variables

Some configuration parameters are not available in the menus because they are not commonly used. However, these parameters can be edited in special cases. This information are published on the LDA support website with more specific documentation, focused on particular applications. Some examples of these parameters are:

- Advanced line monitoring settings: timing, tone setting, etc.;
- Audio sources configuration allowed in emergency or battery (this option will be explained in detail in section 3.6.2);
- Use of SD card for pre-recorded messages;
- Equalization parameters customization.

These advanced settings are based on access to internal variables of the unit. Each of these variables has a unique identifier, called ID. Knowing this identifier, the user will be able to consult the variable and even modify its value, if he has the authorization to do so.

To access an advanced configuration variable, the OK and BCK buttons on the user interface must be pressed simultaneously for 2 seconds, then a special screen will be shown in which you can enter the ID. If necessary, the user will be asked to register with

the level of access required for the variable, and access will be denied in case of insufficient permission.

3.6.2 Blocking PA sources in battery and emergency

ONE can block the operation of its PA sources, considered non-essential, during special system operation statuses. There are two special statuses: **battery powered** unit operation or **system emergency** status. Upon entering one of these two statuses, the unit will review the routing of all its zones, blocking the use of sources that are not enabled. This blocking is done based on a **priority system**, which will be described below.

The priorities of the system's PA sources, by default, are as follows:

PA Source	Priority level
ACSI-PA microphones	8
Input 1	3
Input 2	2
Input 4 (MIX)	1
Input 3	0

There are two cut-off thresholds, that discriminate which sources can or cannot operate in each status. To enable a source, it must have a priority equal to or greater than the threshold configured for that status. These thresholds are:

- **VA CUT THRESHOLD:** PA sources cut-off threshold in VA (emergency) system status;
- **BATT CUT THRESHOLD:** PA sources cut-off threshold during device battery operation.

In both cases, the **default value is 8**, which indicates that only the ACSI-PA microphones will be able to speak during these statuses, and the rest of the sources will be disabled.

These thresholds **can be customized** by using their respective advanced configuration variables, as shown below:

Variable	ID en v01.00.04.01	ID en v02.00.01.00
DAM_PA_SRC_IN_VA_CUT_THRESHOLD	2519	2299
DAM_PA_SRC_IN_BATT_CUT_THRESHOLD	251A	229A

3.6.3 Equalizers

Adjusting the equalizers for each input and output consists in a common operation that is detailed as follows. Each band is a second order peaking filter.

- **Eq Enable:** To enable or disable (bypass) the equalizer.
- **Eq Settings:**
 - **Band x/y:** Select the band you want to edit and the total bands of this channel.
 - **Freq:** Frequency. 10Hz (<1KHz) and 100Hz (> 1KHz) steps
 - **Gain:** 1dB steps from -10 to +10
 - **Width:** Select between 5 filter widths: Wide2 (Q=0,5); Wide1 (Q=1); Mid (Q=1,41); Narrow1 (Q= 2); Narrow2 (Q= 4)

4 SYSTEM USE

4.1 Main screen.

The home screen will display, at all times, important information as specified in the EN54 standard. The message **PA/VA System <ready>** will be displayed by default, but this message could change to **<FAULT>** or **<EMERGENCY>** depending on the current unit status.

In addition, when the system is idle and an emergency or fault entry occurs, the VA monitor or fault log screen will automatically appear respectively.

4.2 Emergency management. <VA Operator>.

This menu allows manual control and monitoring of the emergency system.

These actions require level 2 access, default **password 0002**.

4.2.1 Launch evacuation and alert. <Launch EVAC/ALERT>

To launch the evacuation or alert, access the **Launch EVAC** or **ALERT** menu respectively, after that select the option for all zones or the individual zone(s) independently.

Both statuses could be activated for a single zone, the system will choose the status with the highest priority (EVAC). In all cases, live messages on emergency microphones have higher priority than messages.

4.2.2 Emergency activation. <Enter EMG>

The **Enter EMG** option puts the system in an emergency status, deactivating PA audio sources (except microphones) and activating emergency volumes but does not reproduce any evacuation messages.

4.2.3 Stop voice announcement. <Silence Zones>

Silencing any or all zones will deactivate the reproduction of evacuation and alert messages in the selected zone(s), still maintaining the evacuation status in the respective zone.

4.2.4 Deactivate emergency. <Reset Zones/Sys EMG>

The **Reset Zones** option allows a reset of the voice alarm condition in the selected zone(s), keeping the system in an emergency status.

Reset System launches a global reset that can also be done from the frontal push button (RST) by pressing it for 2 seconds.

Note: If the emergency was activated remotely, it will reactivate after a few seconds. If the faults persist, they will be reactivated within the usual time required.

4.2.5 VA System monitor. <VA Monitor>

This screen condenses the information about the entire system, zone by zone, indicating faults and emergency status of each one of them. The external zones of distributed systems of several units will be as well shown here (see section 3.5), allowing navigation between all of them with left and right cursors.



Figure 21: VA Monitor screen view

Figure 21 shows an example of this screen. The information is represented as follows:

- Line 1: It will show the index of the currently selected zone and the total number of zones constituting the system. The picture shows zone 3 of a system consisting of 10 zones in total;
- Line 2: It will show the fault status followed by the zone emergency status, both separated by a comma.

Possible fault statuses:

- **OK**: Area without incidents;
- **FLT**: A problem has been detected in the area. For a more advanced diagnosis, it is recommended to consult the fault log.

Possible emergency statuses:

- **IDLE-Muted**: Zone at rest, without active emergency and no routed source;
- **IDLE-PA**: Zone at rest, without active emergency and with a PA source routed;
- **EMG-Active**: Zone in emergency without emergency source or mute active. This status allows PA sources and microphones to be used in the zone. To find out if there are routed PA sources in the area, you should consult the system PA monitor (explained in section 4.3.3);
- **EMG-SILENCED**: Zone in emergency with silent status, indicating that the use of PA sources is blocked;
- **EMG-ALERT**: Zone in emergency, issuing the alert message;
- **EMG-EVAC**: Zone in emergency, issuing the evacuation message;
- **EMG-EMIC**: Zone in emergency, issuing a live voice message from an emergency microphone.

NOTE: in the default configuration, it is usual for all zones to enter the IDLE-Muted status when the system faces an emergency. This is due to a block of the PA sources during this status. This block can be customized through advanced settings, see sections 3.6.1 and 3.6.2.

4.3 Public Address Settings. <PA Operator>

When not in use for evacuation, the system can act as a warning system and/or background music. In this menu, you can configure the usual settings of any public address system.

4.3.1 Volume Settings. <Volume>

It is possible to adjust the overall (master) volume and the input volume. The input adjustment range is -100dB to + 12dB. The overall volume can be between -100dB and 0dB.

The overall volume can also be adjusted directly from the main screen, using the up and down buttons.

4.3.2 Matrix. <Matrix>

In the **Matrix** menu, you can manage the PA sources and their assignment to each zone.

For each zone, inputs 1 and 2 may or may not be allowed- these inputs are intended for microphones that will be activated temporarily by user.

BGM stands for "background music", this source will remain active by selecting between input 3 and the internal mixer (Input 4 mix).

Example: Zone 1

In 1: Yes - No

In 2: Yes - No

BGM: < In3 | In4Mix | None >

The source priority management system will decide which signal goes to each zone when multiple zones are active. From highest to lowest priority you have: Emergency microphone, evacuation message, alert message, MPS microphones, input 1, input 2, inputMix, and finally Input 3.

4.3.3 Monitor. <Monitor>

The monitoring menu allows you to view the status of the zones and the inputs of the unit. You will be able to see these parameters:

Zones:

- **Source:** Audio source currently assigned to the zone.
- **Vumeter:** Current audio level.
- **Lab:** Label or name configured for the zone.

Inputs:

- **Vumeter:** Current audio level.
- **Lab:** Label or name configured for the input.

4.4 System monitor. <Sys Monitor>

This menu includes fault and emergency logs, status and system information.

Common structure of the LOGs screen

In all cases, the display of logs on screen follows this structure:

- **Upper line:**
 - Current list information: **FLT**, **EMG** or **SYS**
 - Displayed entry **number** / **Total** entries in the log.
 - Use the right **>** or left **<** keys to change the entry number

- **Lower line:** Up and down keys change the visible information between these options:
 - Event description.
 - Status: (only for the fault LOG) It indicates whether it is active or has been resolved.
 - Date when the fault occurred.
 - Time when the fault occurred.
 - Internal code of the registered entry.

4.4.1 VA system monitor. <VA Monitor>

This option allows you to access the same information screen that has already been described in section 4.2.5. It is replicated here, so that users with L1 level can also access this information, since the “VA Operator” menu requires L2 access level.

4.4.2 Emergency log. <EMG_Log>

Events related to emergency management, reproduction of evacuation and alert messages, operations from the fire panel, etc. are registered.

4.4.3 Fault Log. <FLT_Log>

It reports the faults detected in accordance with the monitoring required by the EN54 standards. By default, this log will show only the active faults, in order to see the history you need to activate the option to see all the faults in the configuration menu of logs <Logs Config>.

4.4.4 System log. <SYS_Log>

It records system events or supervisory information not required by the EN54 standard, but which can be useful for system diagnostics.

4.4.5 LOGs configuration. <Logs Config>

Log displays and utility configurations can be made.

- **See Solved FLT:** It can be configured to see all faults or only active faults.
- **View Interval:** It allows configuring the age of past faults that you can see in the LOG. It indicates the number of **days** since the fault occurred. The number **0** allows you to see all the faults since the device was turned on. Number **365** shows all existing faults.
- **Export Logs:** It exports the logs to the USB memory to be able to see them from a PC. They are exported in a DATAxx slot of your choice and can be seen in .txt files.
- **Erase Logs:** It erases all internal logs.

4.4.6 System information <Sys Info>

It shows the most relevant information of the system, distributed in several categories:

a) Device

Device specific information, such as its address in the system, firmware version, bootloader version, serial number and name (“location” field).

b) System

General system information, whether it is a distributed system with more than one device or a single device. Here the “system UID” (unique identifier of the system) will be shown, as well as the number of zones and devices that make it up. In addition, a “Device Monitor” submenu is included, allowing access to the following information, for each of the devices constituting the system:

- Link status.
- Number of zones.
- ID of your first zone.
- Device identification (by launching this action, the selected device will perform a test of its indicator, allowing the user to identify it).

c) Date/Time

This category allows you to view the current date and time of the system. It will not be possible to modify them from this screen. To do that, it will be necessary to access through the configuration menu, following the path /Configuration/System/Date-Time.

4.4.7 Test

It performs a 5 seconds indicator test.

5 MAINTENANCE INSTRUCTIONS

The device requires reduced periodic maintenance.

The periodicity of the maintenance must be adjusted according to the device installation conditions.

Typical operations:

- Check the indicator and fault log. Weekly
- Clean the air inlets and outlets of the unit. Annually
- Check connections and ground connection of the unit.
- Perform system tests, evacuation drills, etc. to verify the correct operation of the entire system.
- The Battery should be replaced in approximately 3 years, or when it shows malfunctions or fault indications.

5.1 RESOLUTION OF FAULT INDICATIONS

This chapter explains the most common possible fault indicators, in most cases the faults indicated here will be triggered by an error in the configuration of the device, so it is recommended to check section 3.3 “Configuration”.

5.1.1 Loss of system date and time

The device will indicate an incorrect date and time fault (“*date-time invalid*”) when these values have not been configured or have been erased due to prolonged power loss. It is a common warning when **carrying out the first installation** of the unit, which does not arise a serious problem since it is a logical consequence of the period of transport and storage to which the device has been subjected.

To solve this error, correct system date and time must be configured. This can be done through an autoseup process or by manual configuration (see sections 3.2 and 3.3.11, respectively).

5.1.2 Cover opening protection

When the cover is removed, the system will indicate a fault. This is a safety measure since there are dangerous voltages inside the device, especially the main power input, to remember that only expert personnel should operate the device when it is powered and open. The system detects it thanks to a switch that is activated with one of the closing screws. The text “Open cover detected” will be displayed in the entry of the fault log.

5.1.3 Speaker lines

In case a short or open circuit has been detected or the impedance has varied by more than 15%, the system will indicate a fault in the loudspeaker line. In the event of a short circuit, the system will protect itself by disconnecting the line until a manual restart is performed.

The normal load range is between 20 and 600 Ohms. In the zone menu, you can see the calibration measurement that has been established for each line. In the event of an error at the time of calibration, the status 'Calib. Error' will be shown. If this fault occurs, check the line. To do this, disconnect the line and measure the impedance with the help of an LCR meter between the cable terminals (+ and -) and between each of the terminals

with ground. Verify that the values correspond to those expected based on the number and power of the existing loudspeakers on the line.

5.1.4 Transmission line with CIE

The system will indicate a transmission fault with the CIE when it is detected that the transmission path is short-circuited or disconnected.

If this fault occurs, check that the connection between the system and the CIE has been made correctly. To debug the fault, disconnect the two ends of the cable connected between the CIE and the device, and measure between the cable terminals with a multimeter on the $k\Omega$ scale. If the measurement result is 0, the line is short-circuited. If the result is 1 (inf), it means that it is open. The line is correct if the result is $20k\Omega$. In either of the first two cases, replace or repair the transmission line.

5.1.5 Power supply

The system will indicate a power fault in either of these situations:

Main power: A fault has occurred in the main power supply (AC power). If this fault has occurred, check that the network power reaches the unit. If so, check the output of the AC/DC source, it should give 15V. In this case, verify that the disconnection switches are ON.

Redundant power: The device monitors the battery charger and the battery. It can register faults related to these devices. It should be noted that the battery has a shorter life time than the system.

If the battery is discharged continuously, the device will indicate a battery fault and will not charge it until it reaches a minimum level of voltage in the battery. In the monitoring menu, you can see the current battery voltage, and if it is below 10.5V it will not be charged. To try to recover the battery, you must use a specific charger, always under supervision.

5.1.6 Link

Each ONE device will supervise its connection with the rest of the devices in the system, for example ACSI devices that have been installed or other ONE devices in a distributed system. In the event of a link fault (LINK), the power supply of the failed units must be checked, as well as the status of the wiring of these connections.

In the case of multi-device distributed systems, a link fault will be indicated when one unit has lost its connection to the master device through the main bus.

5.1.7 System

The system will indicate a system fault when a problem has occurred in the execution of the software, in the memory, or in the required internal devices. Reset the prompt in case it is due to an occasional fault, and if the problem persists proceed to restore a copy of the system configuration, if you have it, or restore to factory data. After this operation, the device should work normally. If not, contact the support / repair service.

In case of data loss, the unit will work in safe mode, this mode uses the default configuration. An unintentional emergency trigger could be generated if the ECI inputs are configured and connected in reverse mode and return to factory data.

6 TECHNICAL SPECIFICATIONS

Model	ONE-500
Power supply	100 - 240V~ 50/60Hz with integrated PFC
Absorption	320W max - 100W at 1/8 output power - 40W AC standby
Frequency response	80 – 20,000Hz +/-1dB
Signal/Noise ratio	SNR <90dB, A weighting (Main Amplifier)
Distortion	<1% following IEC 60268 -15dB. <0,01% pre-out outputs
Gain adjustment	-100dB +10dB, 1dB steps
DSP	Integrated - 48 kHz, 28 bits - 172 MHz
BGM Audio Inputs	Up to 3 x balanced audio 1 V RMS. 10 K Ω , 3 Pin, Euroblock type
Priority audio inputs	2 x balanced audio 1 V RMS. 10 K Ω , 4 Pin, Euroblock type (GPIO)
General Control (CIE)	2 x control I/O + 6 Zone I/O, TTL Contact 0-5 V. RS-485 MODBUS
LDA Bus ACSI	1 x balanced audio 1 V RMS. 10 K Ω , RJ-45 female, total 1000m
Connectivity ACSI Link	2 x balanced audio 1 V RMS. 10 K Ω , RJ-45 female, total 500m
Preamplified Audio Outputs	4 x balanced audio 1 V RMS. 100 Ω , 3 Pin, Euroblock type
Attenuator Control	6 x override 24V DC, 6 x 30mA, 2 Pin, Euroblock type
Emergency control inputs	8 x 0 - 5V DC, supervised inputs, 2 Pin, Euroblock type
Emergency control outputs	2 x contact closure output, N.O., max 60V DC 130mA, 2 Pin, Euroblock type (4 Pin connector)
Maximum Audio I/O	14 x 12
Amplifier	2 x 500W D class @ 70V/100V. Min load 20 Ω
Backup Amplifiers	1 EN 54-16 backup amplifier with automatic priority
Speaker line outputs	6 x 100V audio. Minimum impedance 20 Ω 500W (outputs 1 and 2), 80 Ω 120W rest, 2 Pin Euroblock type
Output power	500 W(Pink noise 1/8) . 200W RMS following EN-54-16
Protection	Overheat, infrasonic, short circuit, slow start, overload
Emergency power	181x76x167mm battery housing, up to 22Ah
Battery charger	Integrated, intelligent load up to 3 amperios
Screen	Backlit LCD 2 rows x 16 characters
Operating condition	From -5° C to +45° C – from 23 °F to 113 °F From 5% to 95% relative humidity (no condensation)
Finish	Materials: Fe and AL Colors: RAL7016 and RAL9005
Weight	7.5 Kg / 15.76 lb (without battery)
Dimensions (A x H x P)	453mm x 88mm x 455mm / 18.2" x 3.46" x 18"
Supplied Accessories	Male Euroblock type connectors, installation screws, 4 x rubber adapter.

6.1 EN54-16 functions

ONE system controller implements all the mandatory functions complying with the EN54-16:2008 standard. It also includes the following optional certified functionalities:

1. Audible advice
2. Phased evacuation
3. Manual mute of voice-activated alarm condition
4. Manual reset of voice-activated alarm condition
5. Voice-activated alarm condition output
6. CIE connection fault indication
7. Fault indication relative to voice alarm zones
8. Manual voice alarm control
9. Interface to external control devices
10. Redundant power amplifiers

Auxiliary functions

1. Background music programs distribution
2. Zonal microphones call management
3. Channel I/O independent audio signal digital processing
4. Prerecorded messages player
5. LDA Sound Enhancer
6. Recording output
7. Control output for attenuators
8. 3-band input parametric equalizer per channel
9. 7-band output parametric equalizer
10. Loudness Compensation

QUICK INSTALLATION GUIDE

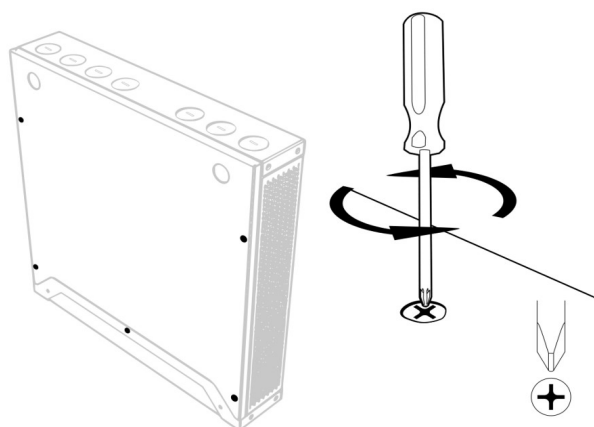

1.- Open the lid. Remove the 5 marked screws:

2.- With the help of a flat screwdriver remove the necessary cable glands depending on the amount of cables to install.

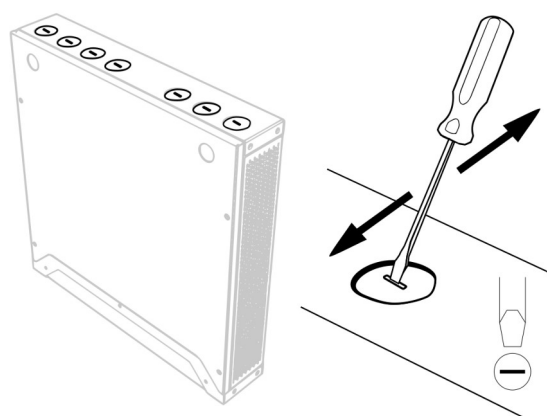

3.- Make the connections inside:

- Speaker lines: (Follow the order from 1 to 6 without leaving gaps, otherwise they will not be detected by the autoseup function)
- Install the battery charger card and battery.
- Connect the audio inputs, microphones, connections to the fire panel and the main power cable.

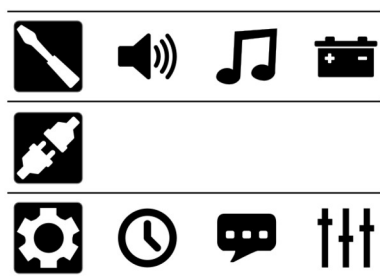
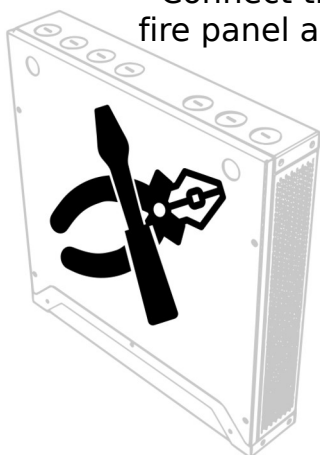

4.- Once the connections have been made, close the lid to avoid the intrusion detection warning. Connect the power.

5.- In the on-screen menus, go to Configuration/Device/Run Autoseup, entering the password L3 (default 0003). Press OK to launch the automatic configuration.

