



KX12

USER GUIDE English

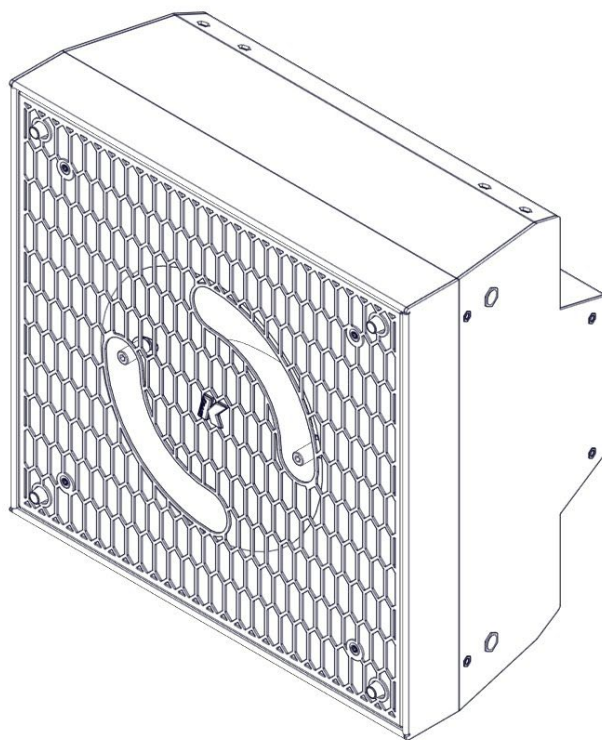

TABLE OF CONTENTS

SYMBOLS	3
1. INTRODUCTION	4
2. KEY FEATURES	4
3. APPLICATIONS.....	4
4. SAFETY INFORMATION.....	5
5. UNPACKING	6
6. PRODUCT OVERVIEW.....	6
7. WIRING	7
8. HORN ORIENTATION	8
9. RIGGING.....	9
9.1 SUSPENDING THE KX12 WITH A FLY BAR.....	9
9.2 WALL-MOUNTING THE KX12	14
9.3 STANDING THE KX12 ON A KMT SUBWOOFER	15
10. SERVICE	20
11. TECHNICAL SPECIFICATIONS.....	21
12. CERTIFICATION	22

SYMBOLS



K-array declares that this device is in compliance with applicable CE standards and regulations. Before putting the device into operation, please observe the respective country-specific regulations!



Waste Electrical and Electronic Equipment (WEEE)
Please dispose of this product at the end of its operational lifetime by bringing it to your local collection point or recycling center for such equipment.



This symbol alerts the user to the presence of recommendations about the product's use and maintenance.



Warning: DANGEROUS VOLTAGE.
Terminals marked with this symbol carry a risk of **electric shock**, therefore external wiring connected to these terminals requires installation by a qualified professional or the use of ready-made leads or cords.



This symbol alerts the user to the presence of recommendations about product's use and maintenance.



This device complies with the Restriction of Hazardous Substances Directive.

1. INTRODUCTION

Designed to be consistently unique like all the unique K-array products, the KX12 is a radical reinterpretation of a traditional coaxial 12" speaker. Its compact shape and different accessories allow the KX12 to perform as a powerful audio point source or as part of a line array.

When high pressure is needed in the foreground with a rapid depreciation once distanced from the source, the KX12 can meet this demand to become one of the most useful tools for an installer. Similar to the Firenze KH7, an asymmetric 100° by 30° horn with an adjustable orientation gives to the speaker an added value providing two modes of coverage to choose from to meet the needs of different installations.

Additionally, dedicated accessories assist in the set up of joining, flying and stacking the speaker, making it a perfect line array component.

Its steel chassis offers maximum rigidity in a minimum size. The speaker delivers a continuous SPL of 127 dB and has a frequency range of 120 Hz to 19 kHz and it is compatible with all K-array KMT subwoofers.

2. KEY FEATURES

- Unique performance-to-size ratio
- Asymmetrical horizontal and vertical coverage
- Variable angle array design
- Stainless steel chassis
- Customized colors (only under specific request)

3. APPLICATIONS

- Clubs, DJ
- Theaters, Concert halls
- Houses of worship
- Portable and installed AV systems
- Cinema and special effects
- Theme parks
- Optimized for KMT18, KMT21, KMT218, KA84

4. SAFETY INFORMATION



Warning: failure to follow these safety instructions could result in injury or damage to the device or other property.

IMPORTANT SAFETY INSTRUCTIONS

- Read these instructions.
 - Keep this instructions.
 - Heed all warnings.
 - Follow all instructions and keep all warnings.
 - Only use attachments/accessories specified by the manufacturer.
- 

 - Use only with the cart, stand, tripod, bracket, or table specified by the manufacturer or sold with the apparatus.
 - When a cart is used, use caution when moving the cart/apparatus combination to avoid injury from tipover.
- **Avoiding hearing damage.** Professional loudspeakers are capable of producing extremely high sound levels and should be used carefully. Never stand close to loudspeakers driven at high volume. Set the volume to a safe level. You can adapt over time to a higher volume of sound that over time may sound normal but can be damaging to your hearing. Hearing loss worsens after exposure to a sound level of 90 dB or over for an extended period of time. If you experience ringing in your ears or muffled speech, stop listening and have your hearing checked. The louder the volume, the less time is required before your hearing could be affected.
 - **Choking Hazards.** This device contains small parts, which may present a choking hazard to small children. Keep the device and its accessories away from small children.
 - **Do not make repairs yourself.** Never attempt to disassemble, repair or modify the system yourself. Disassembling the unit may cause damage that is not covered under the warranty. The device contains no user-serviceable parts. Repairs should only be performed by factory trained service personnel.
 - **Sound distortion.** Do not operate speakers for an extended period of time with sound distortion. This is an indication of malfunction, which in turn can generate heat and result in a fire.
 - **Carrying, handling and installing the device.** The device contains sensitive components. Do not drop, disassemble, open, crush, bend, deform, puncture, shred, incinerate, paint, or insert foreign objects into it. If your device has been dropped or damaged, unplug the power cable immediately.
 - **Setup.** Set up your device on a stable, horizontal surface. If combined or mechanically connected with other products, always verify the stability of the resulting system. Install the unit only in a location that can structurally support the weight of the unit and far away from interference with the stability of the system. Ensure the wind does not interfere with the system's stability, taking extra securities such as chains, weights, ropes or any other certified anchoring systems. Otherwise a unit could fall, causing property damage, personal injury or even death. The system should only be suspended by qualified personnel following safe rigging practices. Securing fixtures to the building structure are vital. To clarify any doubts you may have, seek help from architects, structural engineers or other specialists.

5. UNPACKING

Each K-array speaker is built to the highest standard and thoroughly inspected before leaving the factory. Upon arrival, carefully inspect the shipping carton, then examine and test your new amplifier. If you find any damage, immediately notify the shipping company. Only the consignee may institute a claim procedure regarding the system's electronic equipment.

6. PRODUCT OVERVIEW

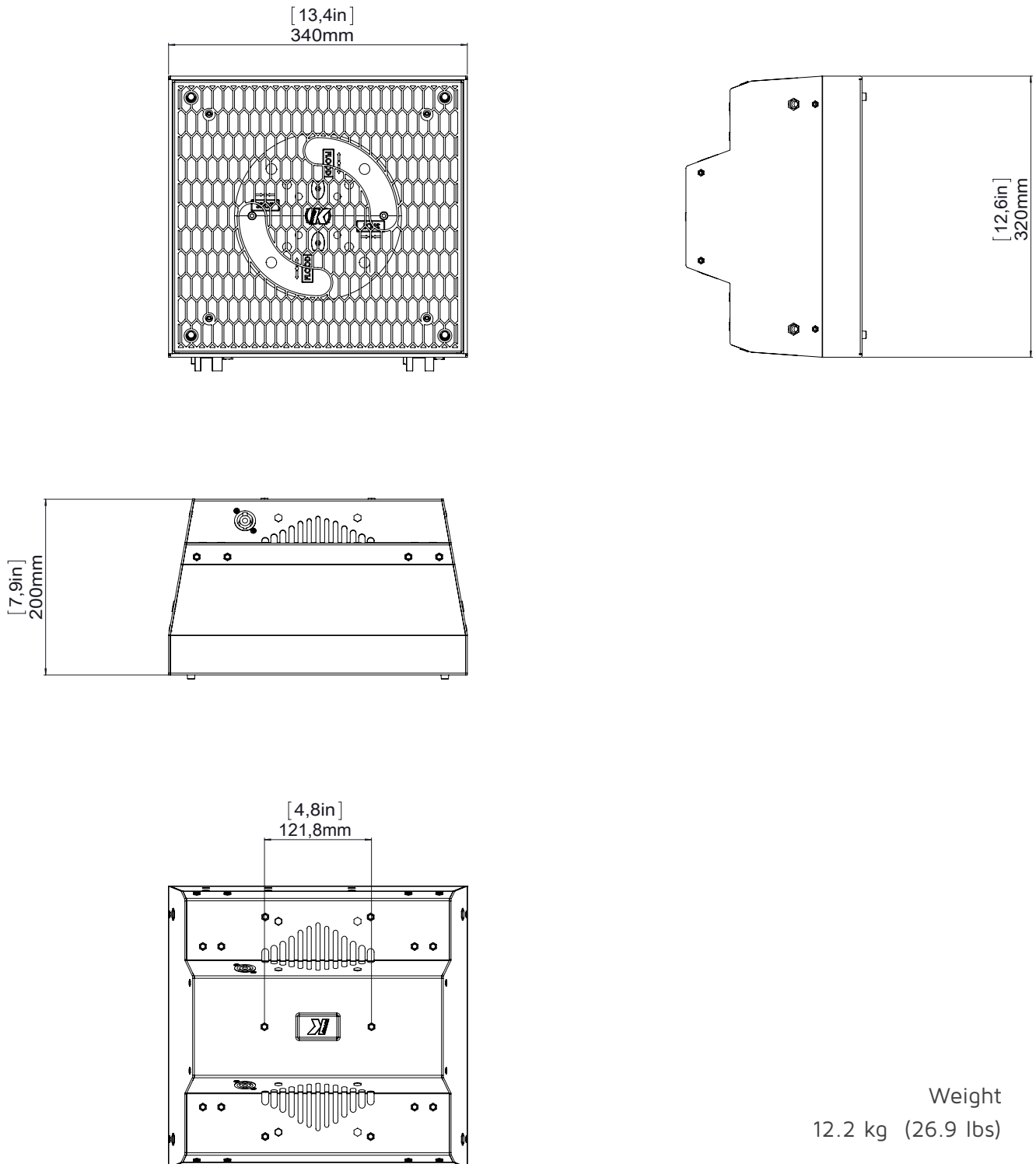

7. WIRING

KX12's internal wiring is designed to pick up the audio power signal from pins 1+ / 1- of a Speakon NL4 connector. Pins 1+ and 1-, such as pins 2+ and 2-, are directly wired from one socket to the other, so that the two sockets are equivalent and can connect the speaker to the amplifier or to another KX12 driven in parallel by the same amplifier channel.

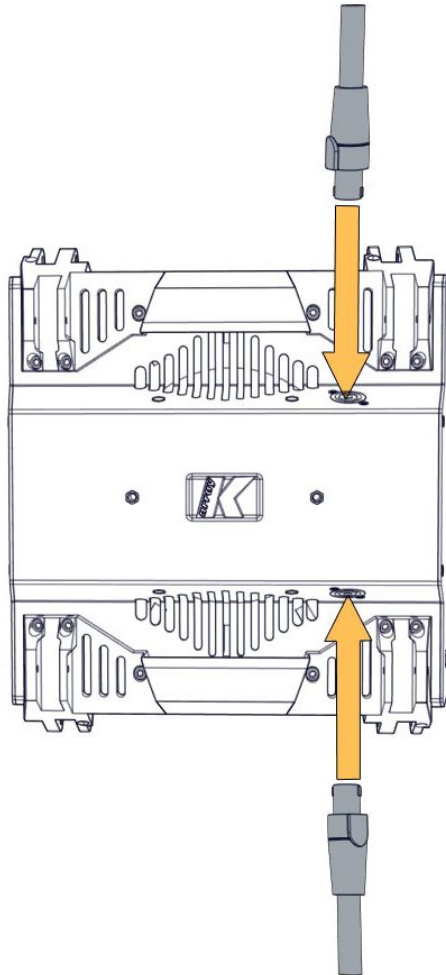

NOTE:

The K-array KA84 amplifier can drive up to two KX12 units per channel

8. HORN ORIENTATION

The KX12 features a 12" woofer and a compression driver coupled to an asymmetric horn. Because the horn is asymmetric, its sound dispersion pattern is different in respect to its axes: the sound dispersion is wide along the axis labeled FLOOD and narrow along the axis labeled SPOT.

The horn can be manually rotated 90° using the two handles situated at the front.

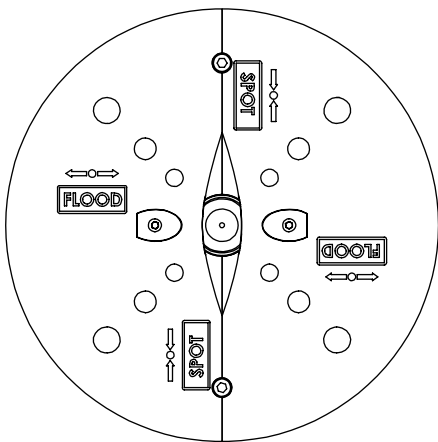
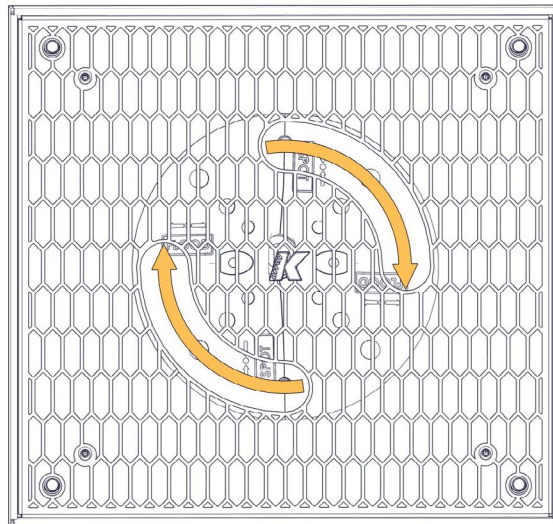

In this position the sound dispersion pattern is wide (FLOOD - 100°) in the horizontal plane and narrow (SPOT - 30°) in the vertical plane.

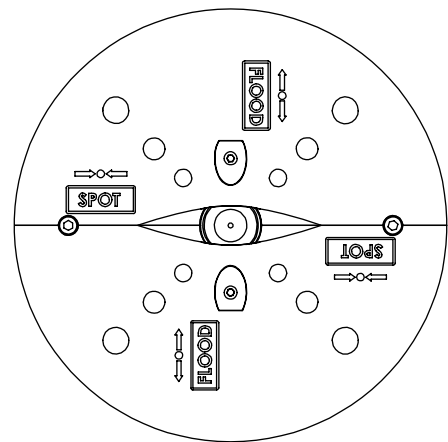

In this position the sound dispersion pattern is narrow (SPOT - 30°) in the horizontal plane and wide (FLOOD - 100°) in the vertical plane.

TIP

If you connect more units together to form a vertical array, make sure to orient all horns in vertical (above picture on the left) so that they are aligned in the same direction of the array. This will assure a wide horizontal coverage with a narrow vertical dispersion.

9. RIGGING

K-array offers a variety of dedicated accessories to mount and connect the KX12 speakers for a wide range of applications.

This section highlights the main accessories available for this product.

9.1 SUSPENDING THE KX12 WITH A FLY BAR

KX12 units can be suspended using the K-FLY2B, a fly bar; K-FLY22, hardware used to connect the first unit to the fly bar; and K-JOINT2B, the hardware that connects a KX12 to the K-FLY22 or to another KX12.

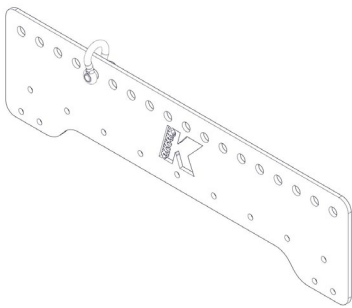

K-FLY2B

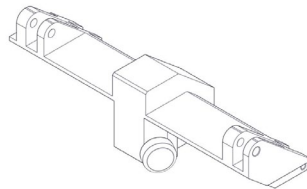

K-FLY22

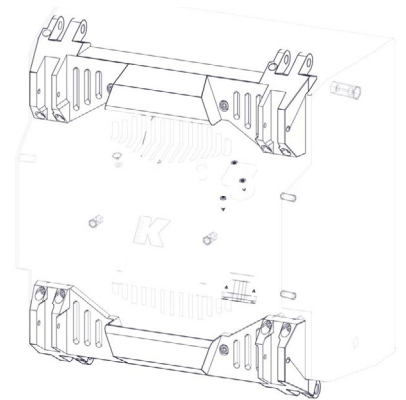

K-JOINT2B

1. First connect the two parts of a K-JOINT2B to each speaker with the provided 5x16 screws.

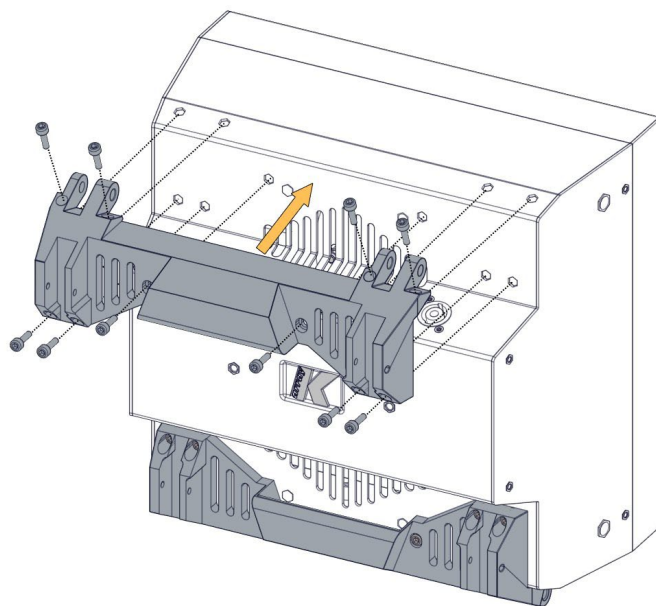

2. Join the K-FLY2B and the K-FLY22 with the two 8x40 piston pins provided with the system.

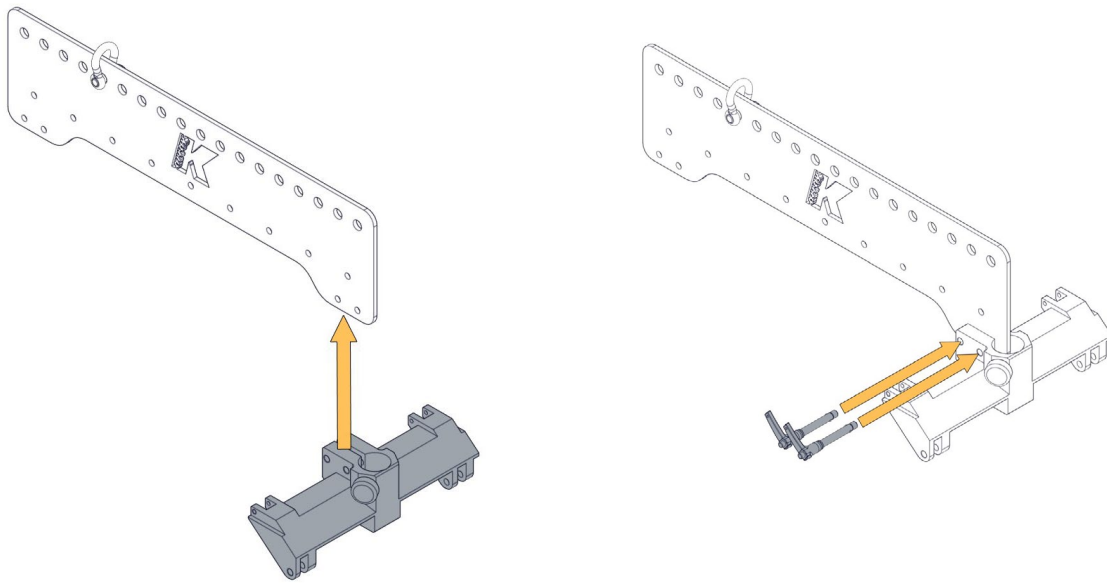

3. Connect the first KX12 unit to the fly bar. Secure with the two 8x40 piston pins provided with the system.

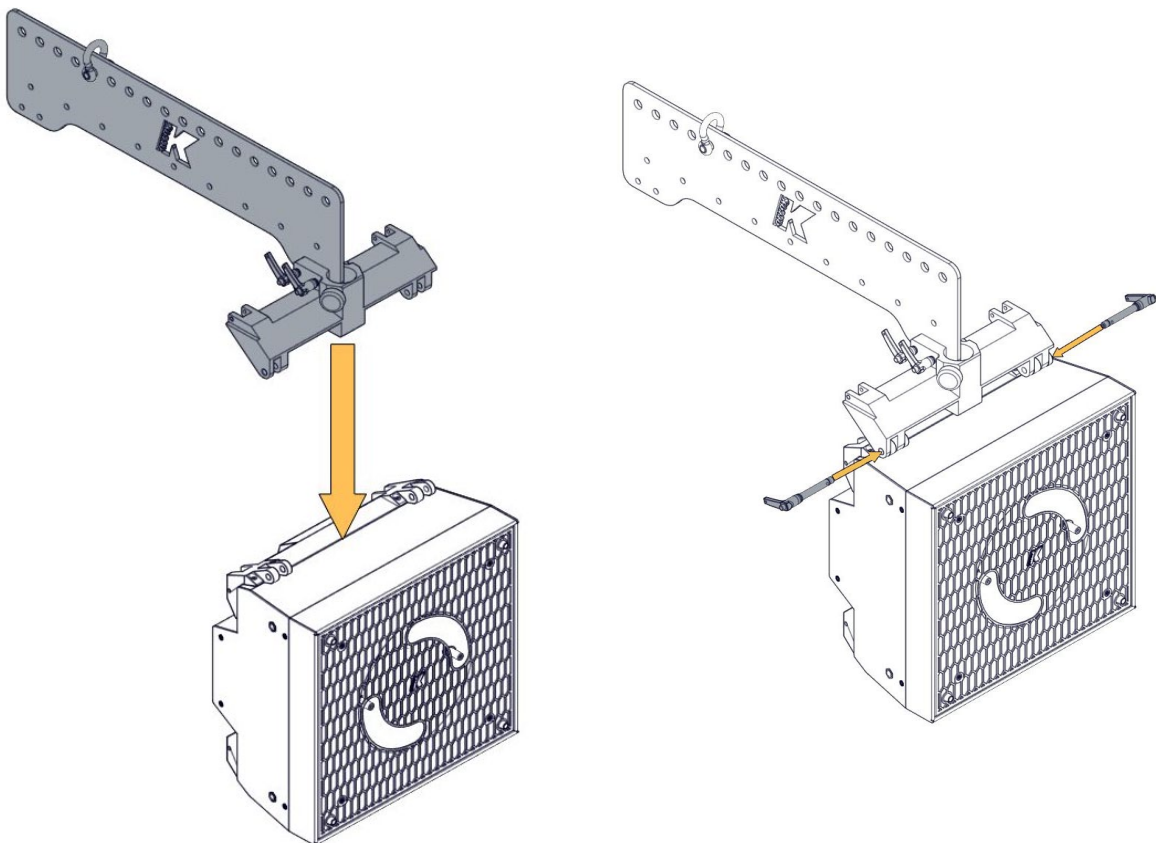

4. Insert two joint blocks and secure each of them with the two 5x30 piston pins provided with the system. The orientation of the joint blocks and the holes used will affect the angle between the fly bar and the KX12, as shown below. We recommend setting an angle of 0° between the fly bar and the first KX12 unit.

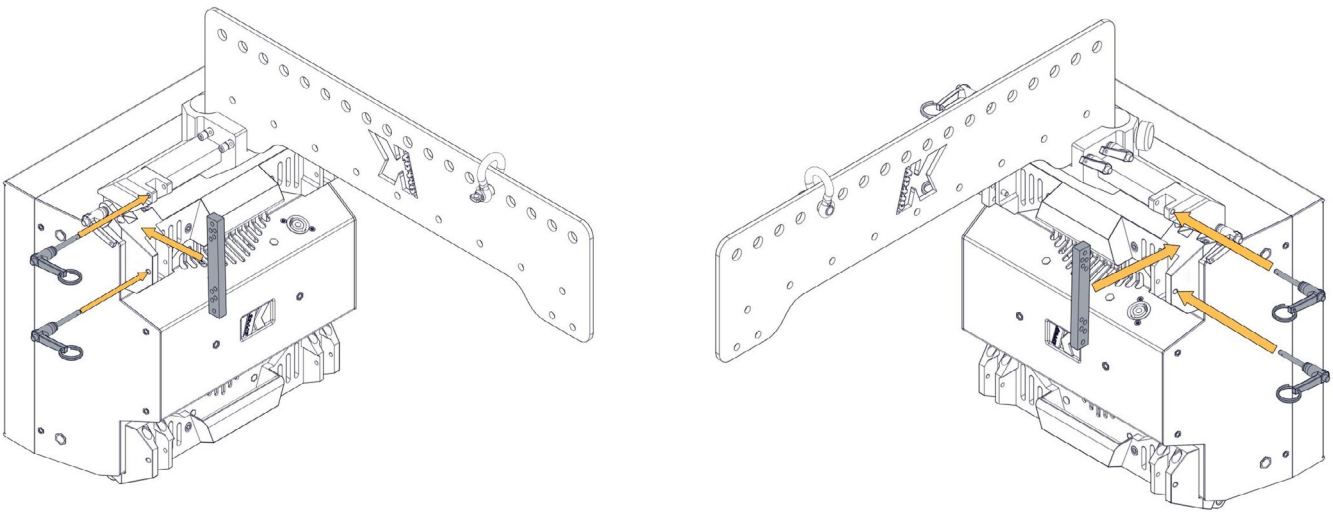

The pictures below show how to regulate the angles

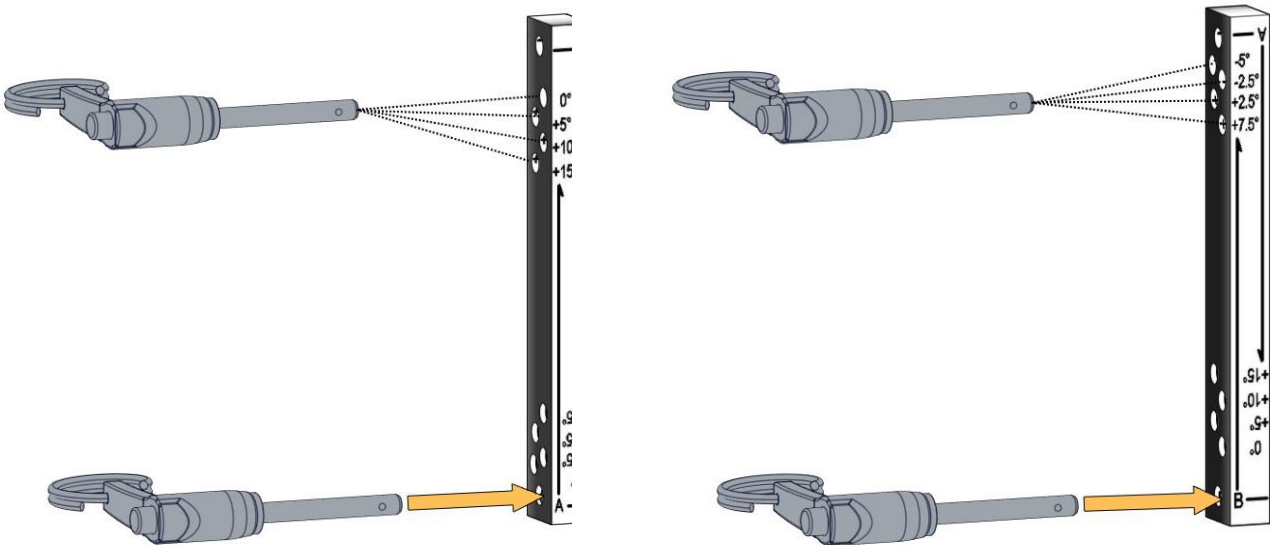

If you want to angle the speaker by 0°, +5°, +10° or +15°, position the joint block so that the letter "A" is at the bottom. Plug a piston pin in the hole labeled "A", adjust the angle of the speaker and plug the second piston pin in the hole corresponding to the desired angle.

If you would like to angle the speaker by -5°, -2.5°, +2.5° or +7.5°, position the joint block so that the letter "B" is at the bottom. Plug a piston pin in the hole labeled "B", adjust the angle of the speaker and plug the second piston pin in the hole corresponding to the desired angle.

5. Position the next unit. Connect the two units with two 8x40 piston pins. Insert the two joints and regulate the angles as explained on the previous page. Secure with four 5x30 piston pins.

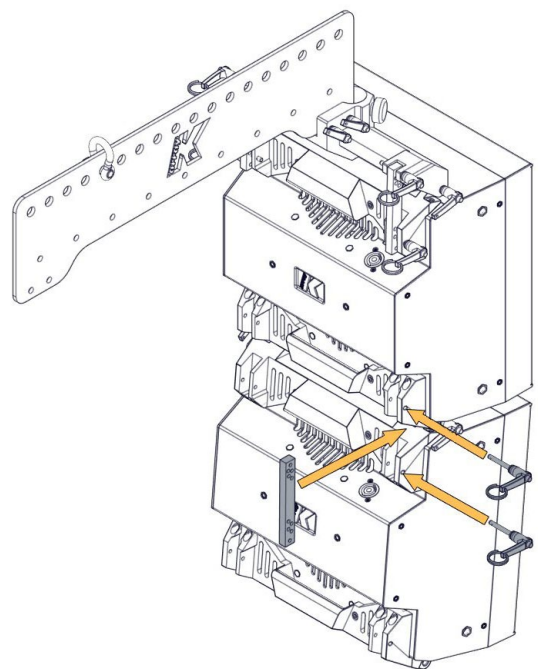
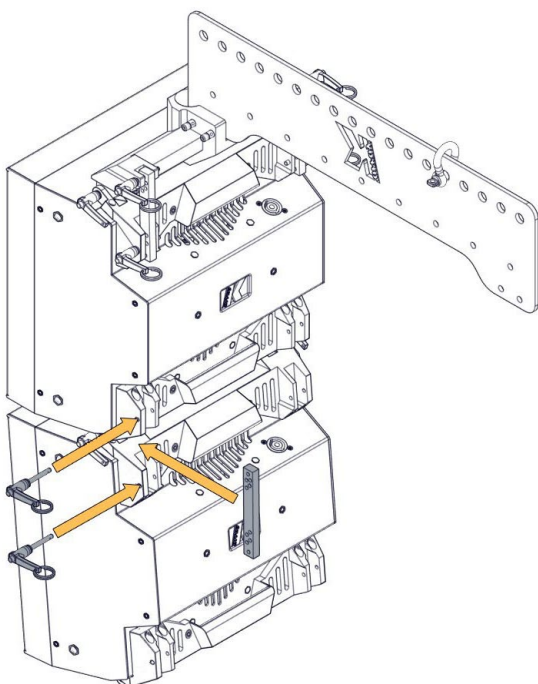
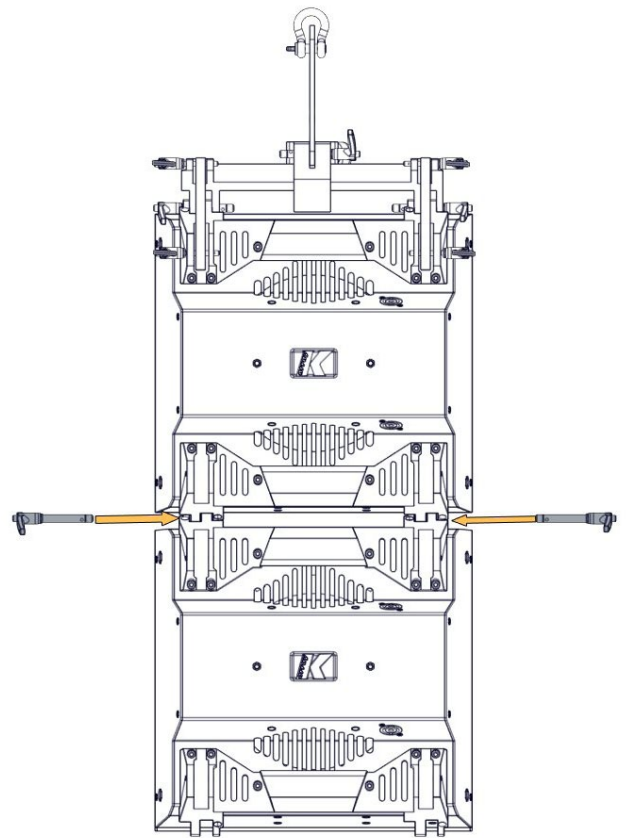
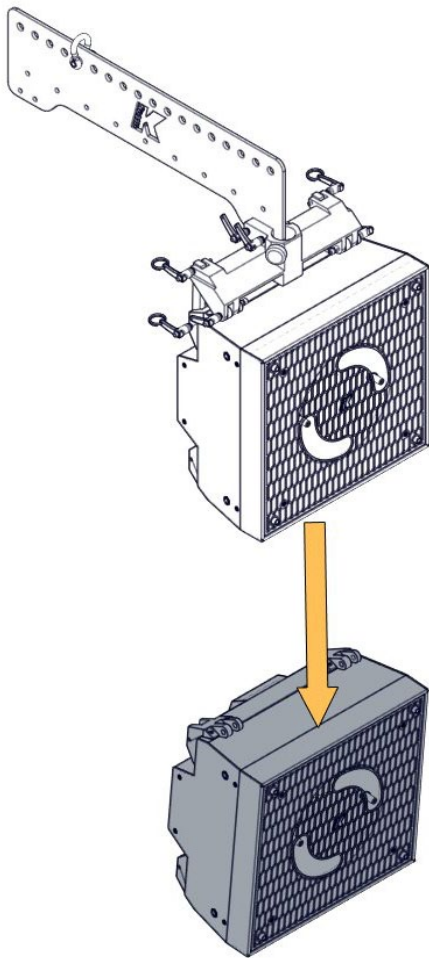

6. Repeat Step 5 to connect the other units.

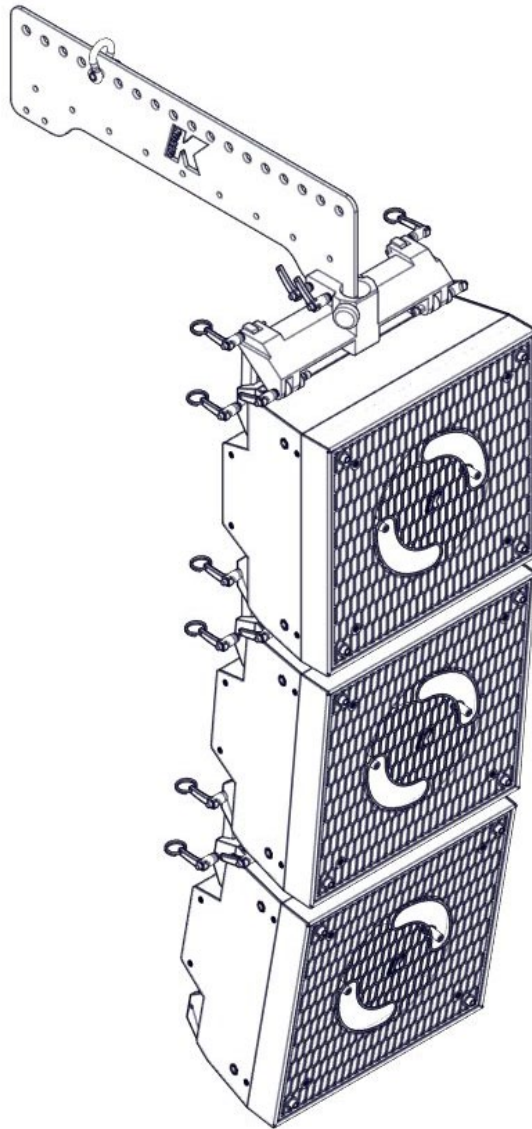

9.2 WALL-MOUNTING THE KX12

The K-WALL2 accessory is used to mount a KX12 unit to a wall.

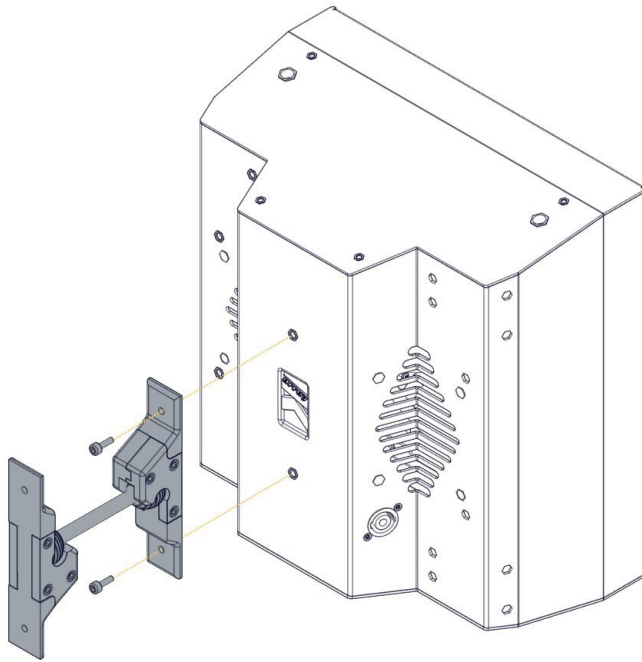

9.3 STANDING THE KX12 ON A KMT SUBWOOFER

KX12 units can be mounted on a KMT subwoofer using the K-FOOT2B-202 and the K-JOINT2B accessories. Excellent examples of this combination are the K-array portable stereo systems KRX202, KRX402 and KRX802.

KRX202

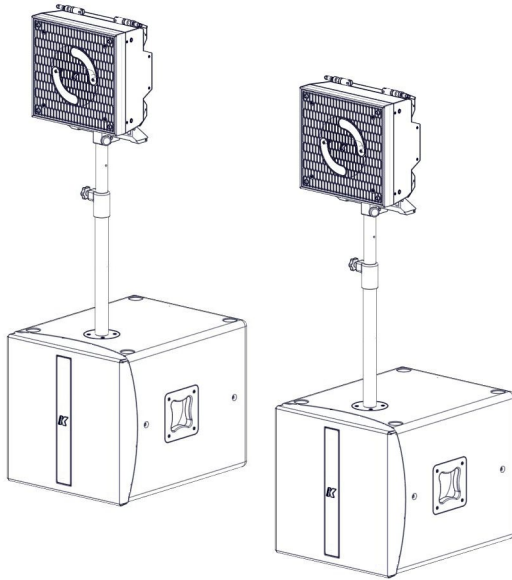

KRX402

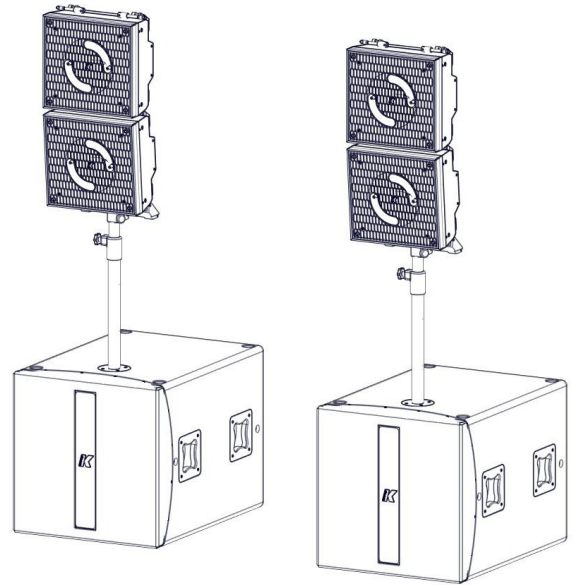

KRX802

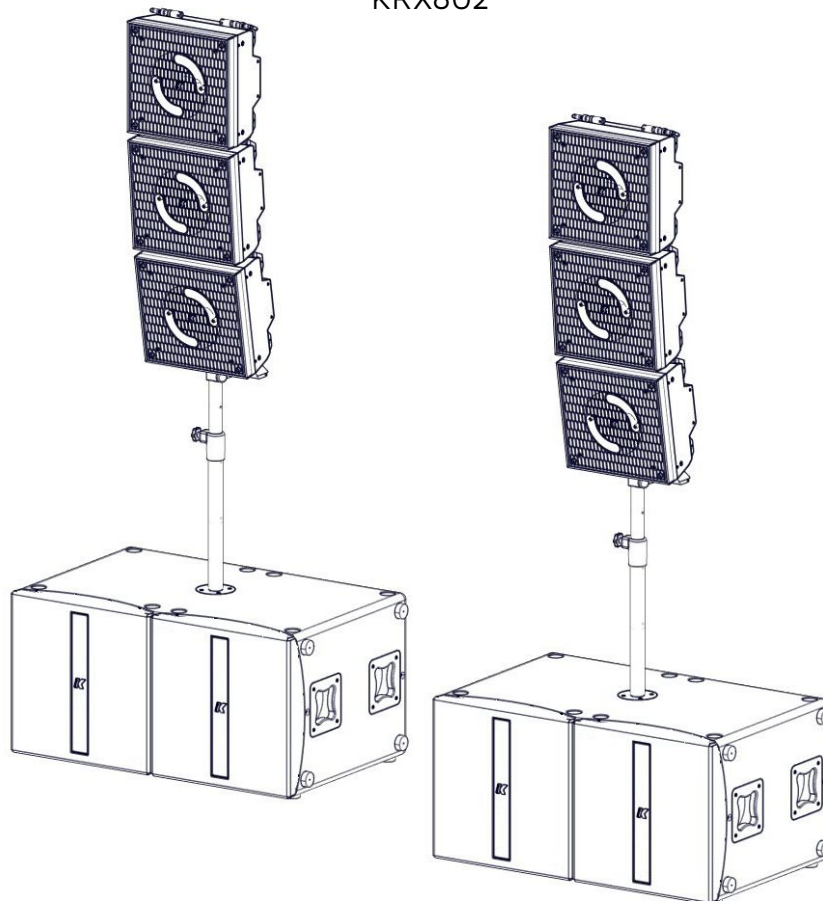

The next step-by-step instructions demonstrate how to mount a KRX802. The mounting procedure for the other systems is not dissimilar.

Below are the accessories needed to mount the system:



K-POLE1

Extendable pole

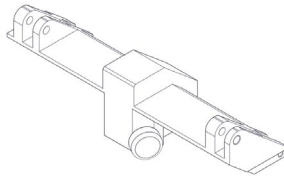

K-FLY2

Adapter to connect the
K-POLE1 to the K-JOINT2B

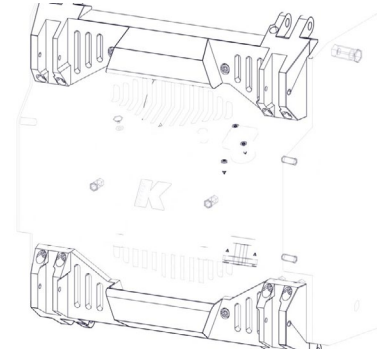

K-JOINT2B

Connecting hardware which you will
need per KX12 unit.

1. Screw the pole into the subwoofer.

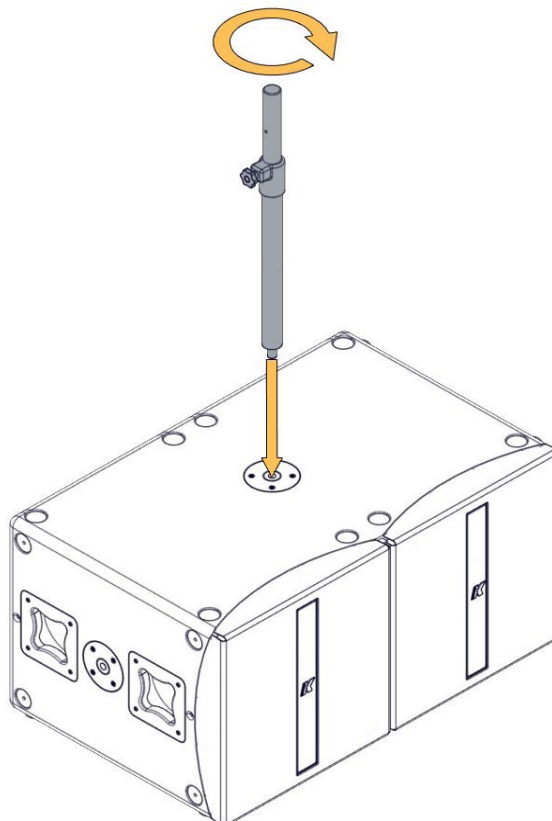

2. Insert the K-FLY22 adapter and screw the knob.

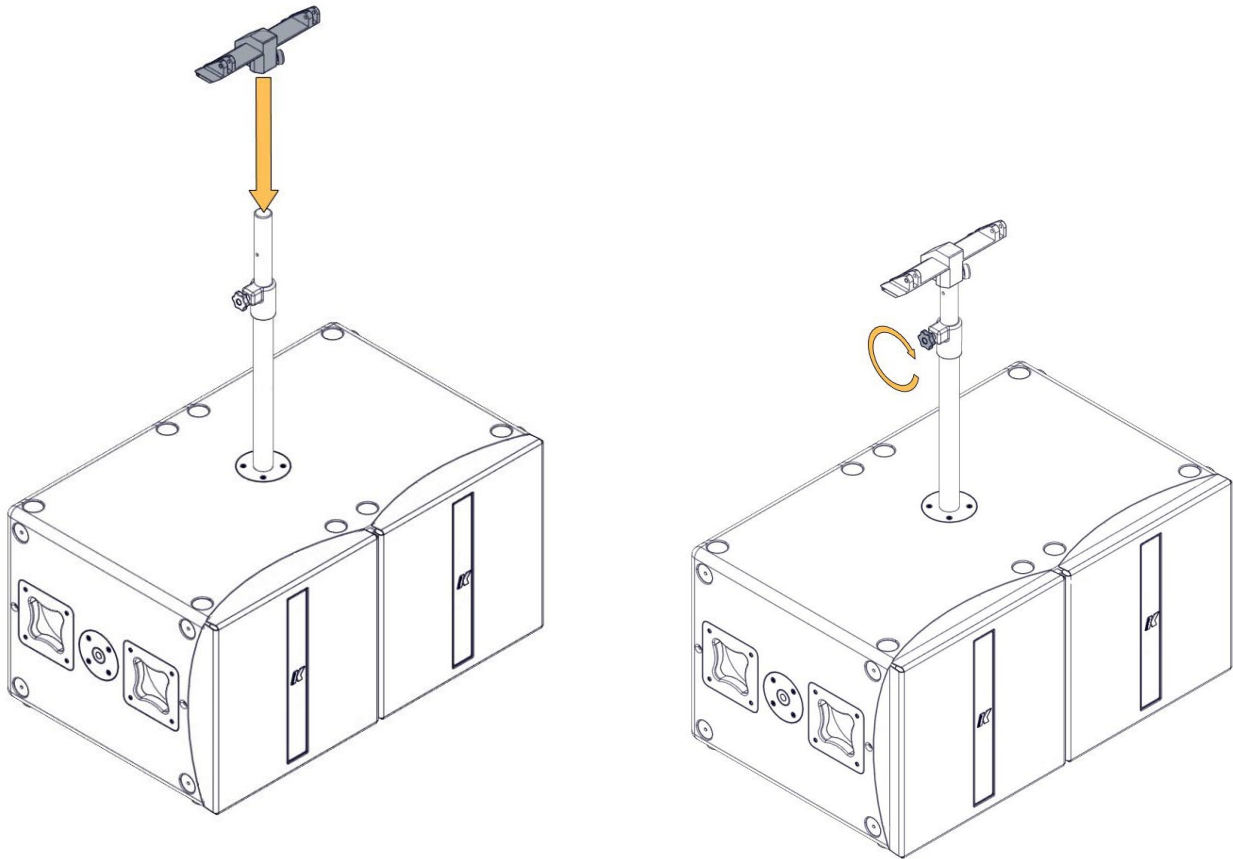

3. Connect a K-JOINT2B to each KX12 unit.

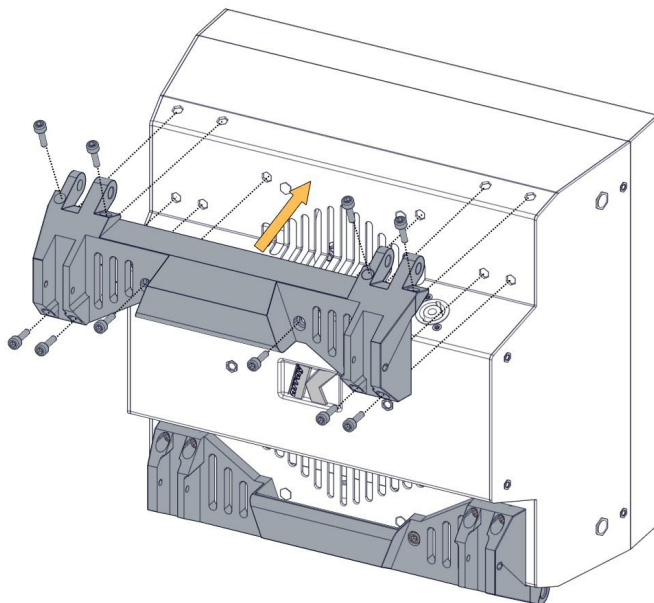

4. Insert the first KX12 unit. Secure with the two 8x40 piston pins provided with the system.

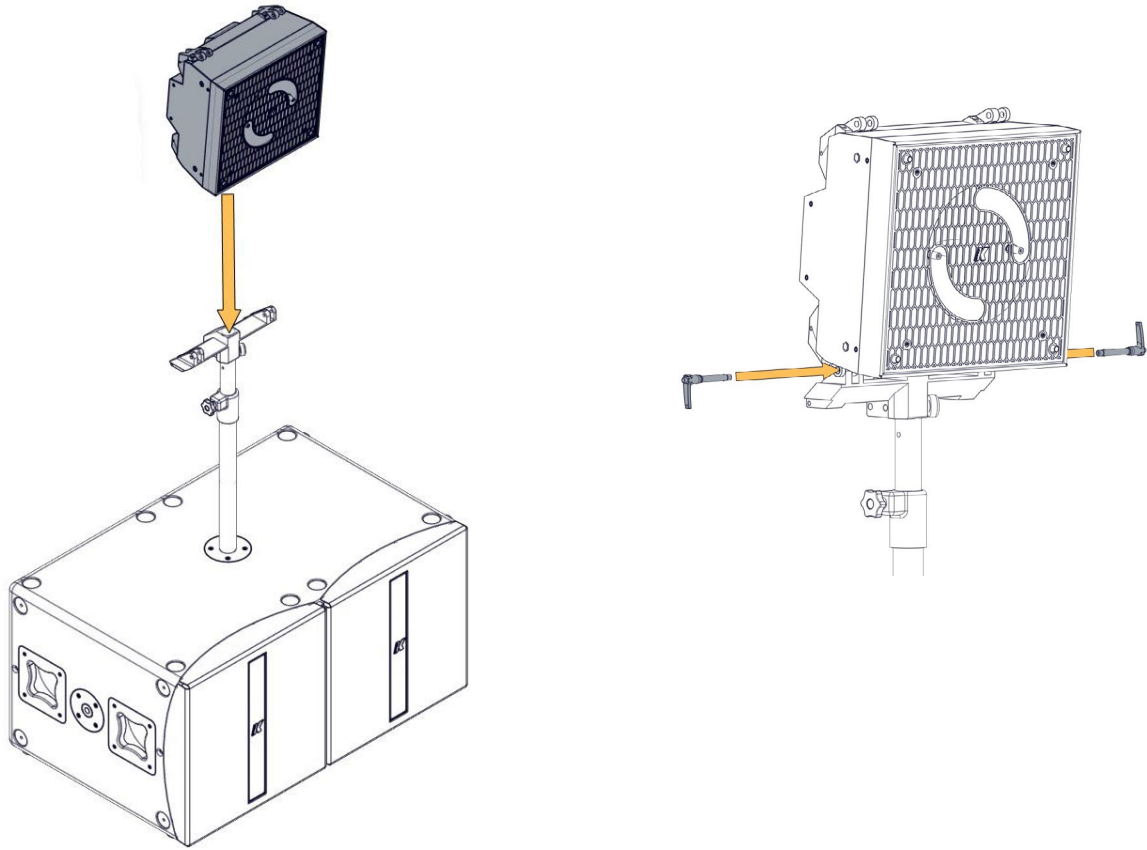

5. Insert two joint blocks and secure each of them with the two 5x30 piston pins provided with the system. The orientation of the joint blocks and the holes used will affect the angle between the K-FLY22 and the KX12, as shown in the next page.

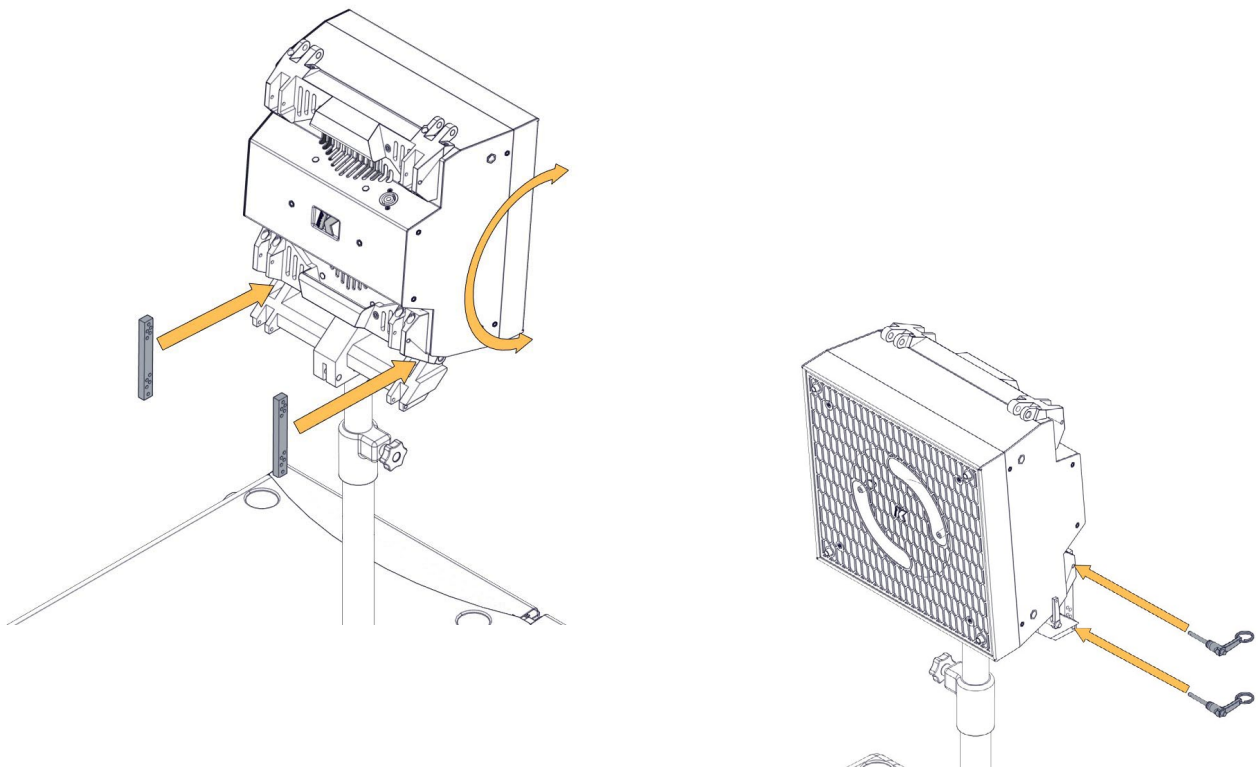

5. Repeat Steps 4 and 5 to add the other units.

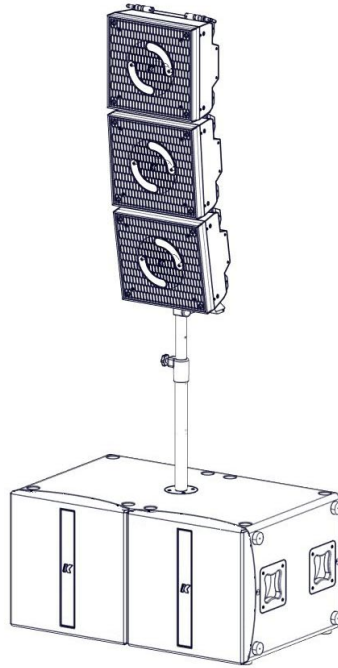

The pictures below show how to regulate the angles

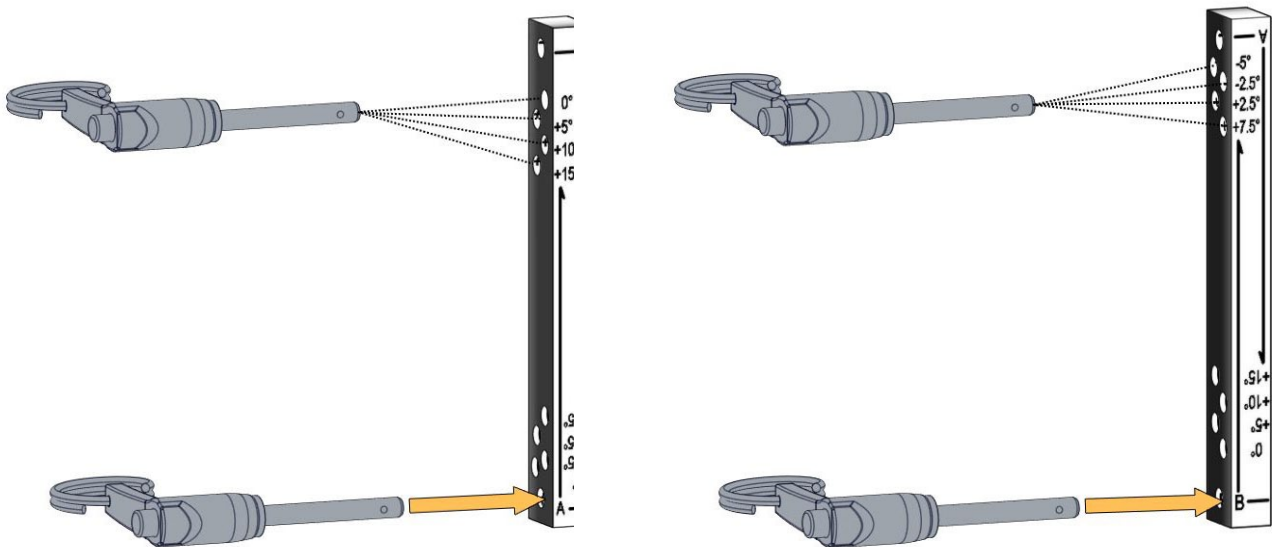

If you want to angle the speaker by 0°, +5°, +10° or +15°, position the joint block so that the letter "A" is at the bottom. Plug a piston pin in the hole labeled "A", adjust the angle of the speaker and plug the second piston pin in the hole corresponding to the desired angle.

If you want to angle the speaker by -5°, -2.5°, +2.5° or +7.5°, position the joint block so that the letter "B" is at the bottom. Plug a piston pin in the hole labeled "B", adjust the angle of the speaker and plug the second piston pin in the hole corresponding to the desired angle.

10. SERVICE

To obtain service:

- 1) Contact the official K-array distributor in your country. Your local distributor will direct you to the appropriate service center.
- 2) If you are calling for service, please have the serial number(s) of the unit(s) available for reference. Ask for Customer Service and be prepared to describe the problem clearly and completely.
- 3) If the problem cannot be resolved over the phone, you may be required to send the unit in for service. In this instance, you will be provided with an RA (Return Authorization) number which should be included on all shipping documents and correspondence regarding the repair. Shipping charges are the responsibility of the purchaser.

Any attempt to modify or replace components of the device will invalidate your warranty. Service must be performed by an authorized K-array service center.



Cleaning:

Use only a soft, dry cloth to clean the product. Do not use any solvents, chemicals, or cleaning solutions containing alcohol, ammonia, or abrasives. Do not use any sprays near the product or allow liquids to spill into any openings.

11. TECHNICAL SPECIFICATIONS

	ACOUSTICS		TRANSDUCERS
Power handling	800 + 200 W		12" Neodymium magnet Woofer with 3" voice coil
Max power	1200 W ⁽¹⁾	COAXIAL	Neodymium magnet compression driver with 2" Voice Coil
Frequency range (-3 dB)	120 Hz – 19 kHz ⁽²⁾		POWER AUDIO INPUT/OUTPUT
Impedance	8 Ω	Connector	2 x 4-pin Speakon
SPL 1W/1mt	102 dB ⁽³⁾	Wiring	1+ 1- (Signal IN & LINK) 2+ 2- (Through)
Maximum SPL	127 dB (cont.) – 133 dB (peak) ⁽⁴⁾		RECOMMENDED AMPLIFIERS
	COVERAGE	Type	KMT18, KMT21, KMT218, KA84
Horizontal	100°/30° (depending on horn orientation)		CERTIFICATION
Vertical	30°/100° (depending on horn orientation)	IP	21
	CROSSOVER		PHYSICAL
Type	External Crossover required	Dimensions	34.0 cm x 32.0 cm x 20.0 cm (13.4" x 12.6" x 7.9")
Frequency	High pass @ 120 Hz, 24 dB/oct suggested minimum	Weight	12.2 kg (26.9 lbs)

Notes for data

1. Maximum RMS applicable power for a musical signal. The reference signal is the one proposed by EIAJ standard
2. With dedicated preset
3. Measured @ 4m then scaled @ 1m
4. Measured with musical signal

New materials and designs are introduced into existing products without prior notice. Present systems may differ in some respects from those presented in this catalogue.

12. CERTIFICATION



DECLARATION OF CONFORMITY

Manufacturer/Importer: K-array s.u.r.l.

Brand: K-ARRAY
Address: via Paolina Romagnoli 17 50038 Scarperia e S. Piero – Firenze - ITALY
Date of Issue: 10 / 03 / 2015
Model(s) Code: KX12 - KX12W - KX12X – KX202K - KX202KX
Declaration: Complies with safety essential requirements of Council Directive

2004/108/EC on the approximation of the Laws of the Member States relating to electromagnetic compatibility.
 2006/95/EC on the harmonisation of the laws of member state relating equipment designed for the use within certain voltage limits
 This declaration applies to all specimens manufactured in accordance with the attached manufacturing drawings which form part of this declaration. Assessment of compliance of the product with the requirements relating to electromagnetic compatibility and low voltage directive was based on the following standards:

EMC:
 EN 55103-1:2009
 EN 55103-2:2009

Marking:



Applying Year: 2015

Applied by: K-array s.u.r.l.
 Via Paolina Romagnoli 17
 50038 Scarperia e S. Piero
 Firenze - Italy
 Tel. +39 055 8487222
 Fax +39 055 8487238

Signed by: Franco Spataro
 Technical Manager

K-array s.r.l. a socio unico società soggetta alla attività di direzione e coordinamento di HP Sound Equipment spa
 P. IVA / VAT / CF 06206990480 - R.E.A. 609589 Cap. soc. i.v. € 100.000,00

Sede legale: via Paolina Romagnoli 50038 Scarperia e San Piero - Firenze - ITALY tel +39 055 8487222 fax +39 055 8487238 info@k-array.com www.k-array.com